

## V4062A,B,D HI-LO-OFF Fluid Power Gas Valve Actuator

### PRODUCT DATA



### APPLICATION

The V4062 Gas Valve Actuator in combination with a V5055, VE5000<sup>a</sup> or V5097 Gas Valve provides three-position control of the gas supply to commercial and industrial burners.

### FEATURES

- When energized, the V4062 Actuator opens the V5055/VE5000/V5097 Gas Valve to the low-fire position. The actuator opens the valve to the fully open position when the line voltage contacts are made.

<sup>a</sup> VE5000 is a European manufactured and approved valve for European use only.

- When used with the V5055, V5097 or VE5000<sup>a</sup> Gas Valve, the combination is rated for final safety shutoff service. Although the V4062 can be used with all V5055 or V5097 Valve models, the V5055/V5097B with characterized guide is recommended for optimum control and low-fire repeatability.
- The standard model has an opening time of 26 seconds at 60 Hz, or 32 seconds at 50 Hz. A fast-opening model is available, with timings of 13 seconds at 60 Hz, or 16 seconds at 50 Hz.
- Maximum closing time is one second, which meets code, standard, insurer requirements.
- Damper shaft models are available with or without spring return; shaft extends out both sides and rides in Delrin bushings; used with standard damper crank arm (part no. 7616BR).
- Red OPEN indicator attached to the actuator stem shows when the valve is even slightly open; yellow SHUT indicator on the valve stem shows only when the gas valve is fully closed.
- Ambient temperature range is -40° to 150°F (-40° to 66°C) for 60 Hz models; -10° to 158°F (23° to 70°C) for 50 Hz and 50/60 Hz models.
- Models available with factory adjusted, field-adjustable, single-pole-double throw (spdt) auxiliary switch rated at 1/2 hp (0.37 kW). Auxiliary switch can be added in the field.
- Low-fire position is adjustable with adjusting wrench, part no. 135796 (included with the actuator).
- Standard enclosure meets NEMA 1 (IP30) general purpose requirements.
- V4062/V5055C,E and V4062/V5097C,E combinations available with a proof-of-closure switch and double valve seal (valve seal overtravel interlock) to meet specific code/standard/insurer requirements.
- Model available to be used with series 60 floating type controller.
- Model available with adjustable maximum flow switch.

### Contents

Application .....	1
Features .....	1
Specifications .....	2
Ordering Information .....	2
Installation .....	4
Wiring .....	6
Adjustments .....	7
Operation .....	8
Service and Checkout .....	8



## SPECIFICATIONS

**IMPORTANT:**

*The specifications given in this publication do not include normal manufacturing tolerances. Therefore, this unit may not exactly match the listed specifications. Also, this product is tested and calibrated under closely controlled conditions, and some minor differences in performance can be expected if those conditions are changed.*

**Models:**

V4062A HI-LO-OFF Gas Valve Actuator.  
 V4062B HI-LO-OFF Gas Valve Actuator, high pressure.  
 V4062D HI-LO-OFF Gas Valve Actuator with proof-of-closure switch. Use with V5055/V5097C,E (double seal) gas valves for valve seal overtravel interlock. Do not use V4062 with V5034 Valve body.

**Electrical Ratings:**

Standard V4062A,D Actuators (Table 1):  
 60 Hz, 26 second opening.  
 50 Hz, 32 second opening.

**Table 1. Standard V4062A,D Actuators.**

Voltage/ Frequency	Opening		Holding	
	W	VA	W	VA
120V/60 Hz	59.5	129	19.0	28.0
100V/50-60 Hz	53.0/42.7	105/80	20.0/17.2	33/29
200V/50-60 Hz	72.01/52.5	160/110	18.4/16.2	28/24

Fast-opening V4062A,D Actuators (Table 2):  
 60 Hz, 13 second opening.  
 50 Hz, 16 second opening.

**Table 2. Fast-opening V4062A,D Actuators.**

Voltage/ Frequency	Opening		Holding	
	W	VA	W	VA
120V/60 Hz	59.5	129	19.0	28.0
220V/50 Hz	84.0	196	17.0	27.0
220V/50 Hz	82.0	180	16.5	26.4
220V-240V; 50-60 Hz <sup>a</sup>	74.5	143.5	13.7	24.8
220V-240V; 50-60 Hz <sup>b</sup>	61.9	112	11.2	20.5

<sup>a</sup> 230V, 50 Hz power supply.

<sup>b</sup> 230V, 60 Hz power supply.

Fast-opening V4062B Actuators (Table 3):  
 60 Hz, 13 second opening.  
 50 Hz, 16 second opening.

**Table 3. Fast-opening V4062B Actuators.**

Voltage/Frequency	Opening		Holding	
	W	VA	W	VA
220V-240V; 50-60 Hz <sup>a</sup>	76.5	150.6	13.3	28.8
220V-240V; 50-60 Hz <sup>b</sup>	64.4	118.2	11	23.2

<sup>a</sup> 230V, 50 Hz power supply.

<sup>b</sup> 230V, 60 Hz power supply.

**Pressure Ratings Of Valve-Actuator Combinations:**

See Table 4.

**Auxiliary Switch And Proof-Of-Closure Switch Ratings:**

See Table 5.

## ORDERING INFORMATION

When purchasing replacement and modernization products from your TRADELINE® wholesaler or distributor, refer to the TRADELINE® Catalog or price sheets for complete ordering number.

If you have additional questions, need further information, or would like to comment on our products or services, please write or phone:

1. Your local Home and Building Control Sales Office (check white pages of your phone directory).
2. Home and Building Control Customer Relations  
 Honeywell, 1885 Douglas Drive North  
 Minneapolis, Minnesota 55422-4386 (800) 328-5111

In Canada—Honeywell Limited/Honeywell Limitée, 35 Dynamic Drive, Scarborough, Ontario M1V 4Z9.

International Sales and Service Offices in all principal cities of the world. Manufacturing in Australia, Canada, Finland, France, Germany, Japan, Mexico, Netherlands, Spain, Taiwan, United Kingdom, U.S.A.

**Table 4. Pressure Ratings of Valve-Actuators Combinations.**

Valve	V4062A,D Actuator <sup>a</sup>				V4062B Actuator			
	Differential <sup>b</sup>		Closeoff <sup>c</sup>		Differential <sup>b</sup>		Closeoff <sup>c</sup>	
	psi	mbar	psi	bar	psi	mbar	psi	bar
V5055A,C; V5097A,C 3/4 to 3 in.	5	340	15	1	15	1000	15	1
V5055A,C 4 in.	3	200	15	1	5	340	15	1
V5055B, V5097B 3/4 to 3 in.	5	340	15	1	15	1000	15	1
V5055B 4 in.	3	200	5	1	5	340	15	1
V5055D,E, 3/4, 1, 1-1/4, 1-1/2; V5097D 3/4 in. to 2 in.	5	340	75	5	25	1700	75	5
V5055D,E; V5097D,E 2, 2-1/2, 3 in.	5	340	45	3	15	1000	45	3

<sup>a</sup> Use a V4062D (with proof-of-closure switch) with a V5055/V5097C or E (with double seal) for valve seal overtravel interlock.

<sup>b</sup> Maximum operating pressure differential.

<sup>c</sup> Maximum closeoff pressure without seal leakage. This is the maximum allowable pressure drop to which a valve may be subjected when fully closed, and is independent of the valve body rating.

**Table 5. Auxiliary Switch and Proof-of-Closure Switch Ratings (1/2 hp [0.37 kW]<sup>a</sup>).**

Load	120V	240V
Full Load	9.8A	4.9A
Locked Rotor	58.8A	29.4A

<sup>a</sup> Maximum total connected power to both switches (if used) is 1800 VA.

**Mounting:**

Mounts directly to V5055/V5097 Valve with two setscrews positioned 90 degrees apart.

Valve and actuator can be mounted in any position (multipoise).

NOTE: 220 to 240 Vac, 50/60 Hz models must be mounted vertically.

**Mounting Dimensions:** See Fig. 1 and Table 7.

**Low-Fire Adjustment:** 0.17 inch to 0.64 inch (with respect to V5055/V5097B Valve) valve stem travel.

NOTE: The low-fire position of the V5055/V5097A,C,D and E Valves differ from the V5055/V5097B. Check the valve flow curves and match the low-fire position to the burner design and valve application.

**Nominal Opening Time:**

Standard Models: 26 sec at 60 Hz; 32 sec at 50 Hz.  
Fast-opening Models: 13 sec at 60 Hz; 16 sec at 50 Hz.

**Closing Time:** 1 sec maximum

**Damper Shaft:** 3/8 in. sq (9.5 mm) for use with 7616BR Damper Crank Arm (not included). Models available with or without damper shaft return spring.

**Maximum Damper Shaft Rotation:** 52 angular degrees.

**Maximum Force:** At 2-11/16 in. (68.3 mm) radius for 7616BR Damper Crank Arm (ordered separately).

NOTE: Damper shaft drives damper crank arm in one direction only; optional return spring is available on damper shaft to turn damper crank arm in opposite direction. See Table 6.

**Table 6. Actuator Torque (With and Without Return Spring).**

V4062 Model	-40°F to +20°F (-40°C to -7°C)		20°F to 150°F (-7°C to +66°C)	
	lb	N	lb	N
Without return spring	5	22.2	20	89.0
With return spring	5	22.2	10	44.5

**Ambient Operating Temperature Rating:**

-40° to 150°F (-40° to 66°C) for 60 Hz models;  
-10° to 158°F (-23° to 70°C) for 50 Hz and 50/60 Hz models.

**Approvals:**

Underwriters Laboratories Inc. Listed: File No. MH1639, Guide No. YIOZ.

Factory Mutual: Approved.

International Approval Services (Joint Venture of the American Gas Association [AGA] and the Canadian Gas Association [CGA]): Certified 60 Hz models only.

Industrial Risk Insurers Acceptable.

Some V4062 Actuators are approved as Class A valves in accordance with EN161:

When used with V5055 Valves: Pin: CE-0063AR1359.

When used with VE5000 Series Valves: Pin: CE-0063AP3075.

**Accessories:**

133568 Auxiliary Switch Bag Assembly.

133569 Proof-of-Closure Switch Bag Assembly. (Must be used with a V5055/V5097C or E with double seal).

135796 Wrench (included with the actuator).

7616BR Damper Crank Arm (damper arm and clip).

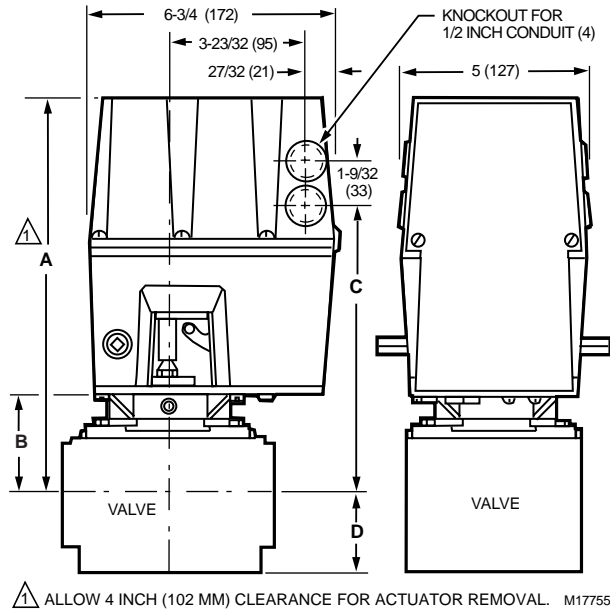

Fig. 1. Approximate mounting dimensions of V4062 Actuators in in. (mm).

Table 7. Approximate Mounting Dimensions of V4062 Actuators with V5055 and V5097 Valves.

Valve Size <sup>a</sup> (in.)	V5055								V5097								
	Dim. A		Dim. B		Dim. C		Dim. D		Dim. A		Dim. B		Dim. C		Dim. D		
	in.	mm	in.	mm	in.	mm	in.	mm	in.	mm	in.	mm	in.	mm	in.	mm	
Small Body	3/4	11-1/8	283	2-3/4	70	8-3/16	208	5-3/4	146	11-1/8	283	2-3/4	70	8-3/16	208	2-1/2	64
	1	11-1/8	283	2-3/4	70	8-3/16	208	5-3/4	146	11-1/8	283	2-3/4	70	8-3/16	208	2-1/2	64
	1-1/4	11-1/8	283	2-3/4	70	8-3/16	208	5-3/4	146	11-1/8	283	2-3/4	70	8-3/16	208	2-1/2	64
	1-1/2	11-1/8	283	2-3/4	70	8-3/16	208	5-3/4	146	11-1/8	283	2-3/4	70	8-3/16	208	2-1/2	64
Large Body	2	11-1/8	286	2-7/8	73	8-5/16	211	8-3/8	213	11-3/4	298	3-3/8	86	8-3/8	213	4	102
	2-1/2	11-3/4	298	3-3/8	86	8-13/16	224	9-1/4	235	11-3/4	298	3-3/8	86	8-3/8	213	4	102
	3	11-3/4	298	3-3/8	86	8-13/16	224	9-1/4	235	11-3/4	298	3-3/8	86	8-3/8	213	4	102
	4	14-1/8	359	5-13/16	148	11-7/32	285	12-1/2	318	—	—	—	—	—	—	—	—

<sup>a</sup> Valve size using accessory pipe adapter fitting.

## INSTALLATION

### When Installing This Product...

1. Read these instructions carefully. Failure to follow them could damage the product or cause a hazardous condition.
2. Check the ratings given in the instructions and on the product to make sure the product is suitable for your application.
3. Installer must be a trained experienced, flame safeguard control technician.
4. After installation is complete, check out product operation as prided in these instructions.

## ⚠ WARNING

### Electrical Shock Hazard.

### Can cause serious injury or death.

Disconnect power supply before making wiring connections to prevent electrical shock and equipment damage.

### IMPORTANT

1. All wiring must comply with all applicable electrical codes, ordinances, and regulations. All wiring must be NEC Class 1.
2. Voltage and frequency of the power supply connected to this control must agree with those marked on the device.
3. Loads connected to the auxiliary switch and/or proof-of-closure switch, if used, must not exceed the ratings given in the Specifications section.
4. When replacing a V6034 Actuator with a V4062, the V5034 Valve body must be changed to a V5055 Valve.
5. Do not attempt to use the V4062 Actuator with the V4055/V5034 Adapter. Differences in stem travel can prevent correct low fire adjustment.

## Install Valve

The actuator is installed directly on the V5055/V5097 body after the valve is installed in the gas supply line. Refer to the instructions packed with the V5055/V5097 Gas Valve for installation details. When installing the valve, assure that:

1. Sufficient clearance is allowed for actuator installation and service.
2. Ambient temperatures at the valve location do not exceed actuator ratings.
3. Position of the valve permits damper hookup if one is controlled.

## Install Accessory Switches (If Needed)

An spdt switch can be installed to operate an auxiliary load up to 1/2 hp (0.37 kW). The switch can be adjusted to operate at any point in the valve stroke.

A proof-of-closure switch can also be installed with a V5055/V5097C or E Valve (with double seal) on any V4062 Actuator to provide a valve seal overtravel interlock. The spdt proof-of-closure switch is installed to make or break a circuit when the valve is in the closed position. The switch is not adjustable.

**NOTE:** Mark the actuator or valve to indicate any changes made.

To install the switches, proceed as follows:

1. Remove the actuator faceplate (two screws).
2. Remove the silver-colored barrier to expose the actuator stem.
3. Insert the auxiliary switch in the position indicated in Fig. 2. Fasten with two screws through the actuator base.
4. Insert the proof-of-closure switch in the position shown in Fig. 2. The proof-of-closure switch mounts against the side of the actuator housing. The mounting holes are spaced to allow mounting the switch only in the correct position. Fasten with two screws through the actuator base.
5. If only one switch is used, install the narrow barrier included with the switch in the unused space.
6. Mount the actuator before making wiring connections and adjustments to the auxiliary switch.

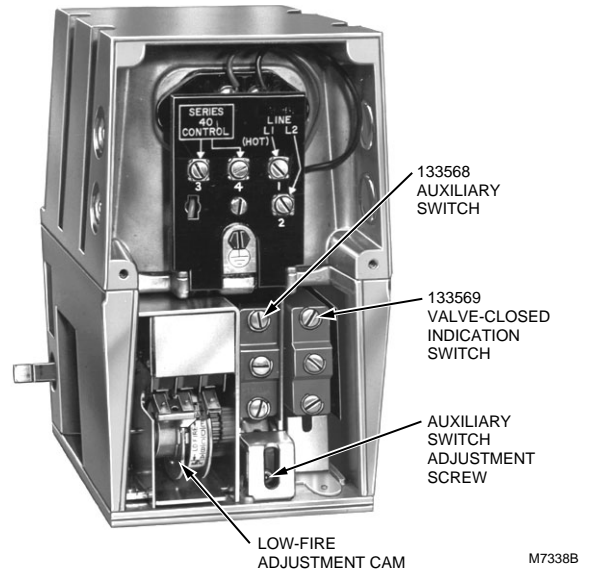

**Fig. 2. V4062 Actuator with cover removed.**

## Mount Actuator On Valve

Check the final position of the V5055/V5097 Valve body to be sure that the actuator will be in the proper position when mounted on the valve. This is especially important when the actuator is used to drive a damper.

If two smaller size valves are mounted very close together, as in an Industrial Risk Insurers type valve train, it may be necessary to mount the actuators off center to provide adequate clearance.

Slip the bottom collar of the actuator over the valve bonnet assembly. Rotate the actuator to the desired position and use a 5/32-inch Allen wrench to securely tighten the two setscrews (50 to 60 lb-in. [5.7 to 6.8 N•m]). Connect the damper linkage, if used. Refer to the instructions packed with the damper crank arm.

## Mount and Adjust 7616BR Damper Crank Arm (If Used)

The damper crank arm provides a maximum travel of 2-5/16 in. (58.7 mm) through a stroke of 52 degrees. See Fig. 3. If the V4062 has a damper shaft return spring, dampers go to the closed position when power is interrupted by the programmer. Refer to the instructions packed with the 7616BR Damper Crank Arm for complete installation information.

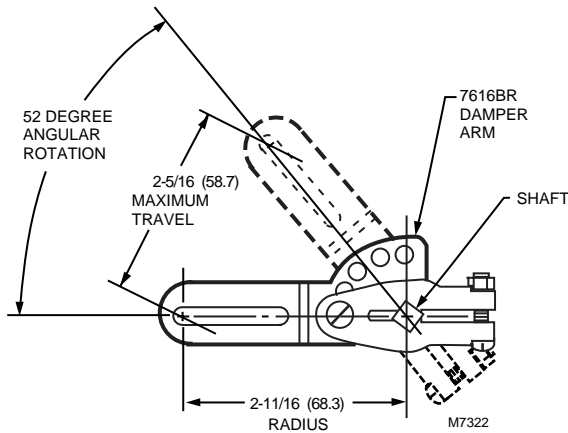

**Fig. 3. 7616BR Damper Crank Arm can be attached to actuator shaft to drive a damper at same time valve is opened.**

## WIRING

Wiring must comply with all applicable electrical codes, ordinances, and regulations. Wiring to the actuator and to the controller must be NEC Class 1.

### **⚠ WARNING**

**Electrical Shock Hazard.**  
**Can cause serious injury or death.**  
 Disconnect power supply before doing any wiring.

Connect the power from the flame safeguard control to terminals 1 and 2 on the V4062 terminal strip, and connect the firing rate controller to terminals 3 and 4. Refer to Fig. 4 for typical connection. Fig. 5 shows the wiring for connecting the Max Flow Limit Switch to the actuator. For other typical system hookups, refer to the instructions packed with the device used to control the valve.

When all wiring connections are complete, replace the actuator faceplate.

### **⚠ CAUTION**

**Equipment Damage Hazard.**  
**Can cause equipment damage or improper and dangerous operation.**  
 Label all wires prior to disconnection when servicing valves. Wiring errors can cause improper and dangerous operation.

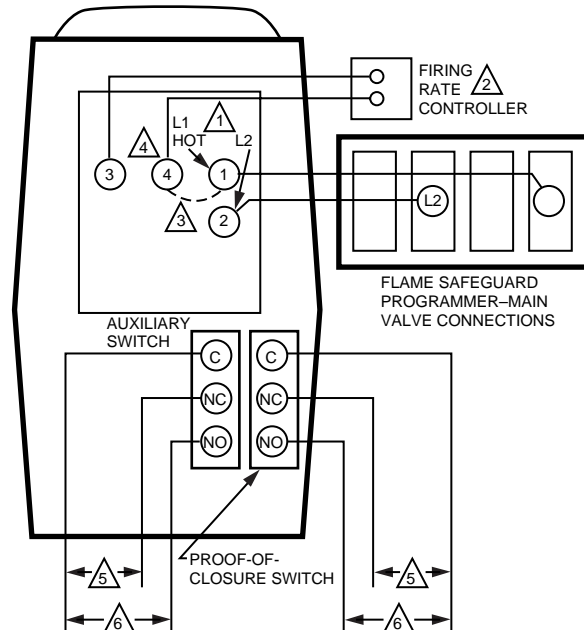

- 1 POWER FROM FLAME SAFEGUARD CONTROL.
- 2 ACTUATOR OPENS TO LOW-FIRE POSITION WHEN FIRING RATE CONTROLLER SWITCH IS OPEN AND LINE VOLTAGE IS SUPPLIED TO TERMINALS L1 AND L2. ACTUATOR OPENS FULLY WHEN THE FIRING RATE CONTROLLER SWITCH IS CLOSED AND POWER IS SUPPLIED TO TERMINALS L1 AND L2.
- 3 INTERNAL JUMPER.
- 4 FOR LOW-FIRE ADJUSTMENT AFTER BURNER IS IN OPERATION. DISCONNECT FIRING RATE CONTROLLER LEADWIRE FROM TERMINAL 4.
- 5 SWITCH BETWEEN THESE TWO LEADS IS CLOSED WHEN VALVE IS SHUT (DE-ENERGIZED).
- 6 SWITCH BETWEEN THESE TWO LEADS IS OPEN WHEN VALVE IS SHUT (DE-ENERGIZED).

**Fig. 4. Typical hookup for V4062 Actuator.**

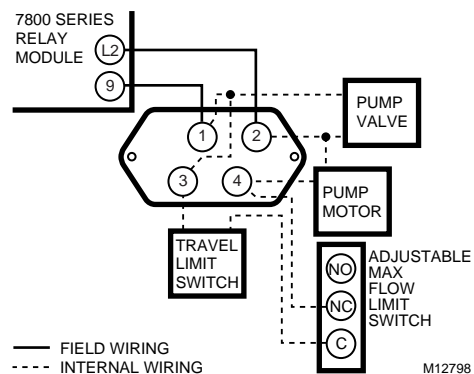

**Fig. 5. Connecting Max Flow Limit Switch to the actuator.**

## ADJUSTMENTS

### Low-Fire Adjustment

The low-fire position is adjustable from 0.16 in. to 0.64 in. (with respect to V5055/V5097B Valve) valve stem travel. A dial on the low-fire cam (Fig. 6) indicates the low-fire setting. Because the cam rotates as the valve opens, scales are marked on the dial so the low-fire setting can be observed with the valve in any position. One scale is visible when the actuator is closed, and the other is visible when it is open. These scales are not independent; the same setting applies to both. The low-fire setting is adjusted either before the actuator is installed or after the entire system is operational. Refer to form 70-8311 for valve flow (capacity) curves.

#### IMPORTANT:

*When using the V4062 with a V5055/V5097C or E Valve (with double seal), match low-fire minimum position to burner and application. Too low a position could result in loss of burner flame. This low-fire position should also be checked at periodic maintenance intervals.*

For most effective use of the V4062/V5055 or V4062/V5097, be sure to select a valve body size closely corresponding to burner capacity. An oversized valve might not allow the low-fire rate to be adjusted to the desired minimum setting.

The V4062 Actuator is shipped from the factory with the low-fire setting at MAX to provide a valve gas flow of approximately 50 to 60 percent, which is adequate for safe lightoff until the final setting can be determined.

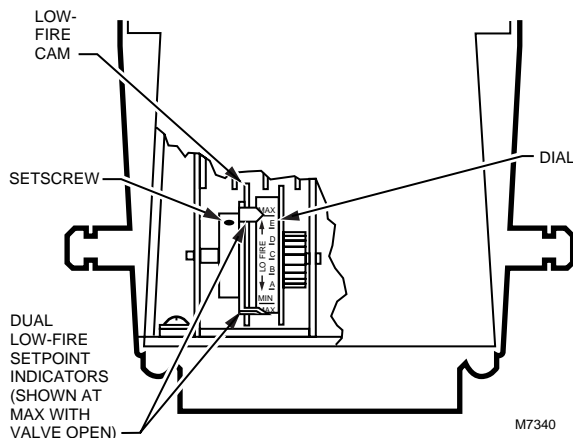

**Fig. 6. Low-fire position can be adjusted from 0.16 in. to 0.64 in. (with respect to V5055/V5097B) valve stem travel.**

### Recommended Procedure

To adjust the low-fire setting without energizing the actuator, proceed as follows:



1. Remove the wiring compartment cover.
2. Manually rotate the cam and dial assembly downward so that the setscrew is accessible from the front of the actuator.
3. Loosen the setscrew on the low-fire cam using the special wrench (supplied—taped to the inside of the actuator cover).
4. Set the cam to the predetermined low-fire setting for the burner being used.
5. Tighten the setscrew in the cam.
6. Replace the wiring compartment cover.

### Alternate Procedure

To adjust the low-fire setting after the burner is in operation, use the following instructions:



1. Remove the wiring compartment cover.
2. Check to be sure the low-fire adjustment is set at MAX to assure a safe lightoff. (Low-fire adjustment is preset at the factory in the MAX position.)
3. Disconnect the firing rate controller leadwire from terminal 4 on the actuator to keep the valve in the low-fire position (Fig. 4).
4. Start the system and establish the main burner flame.
5. Loosen the setscrew in the cam (Fig. 5) with the special wrench. Keep the wrench seated in the setscrew. Rotate the cam slightly downward (by moving the wrench toward the actuator base) to open the bleed valve. The actuator will start to close.
6. When the valve reaches the desired low-fire position, quickly tighten the setscrew and remove the wrench. If the desired low-fire setting is missed, loosen the setscrew and rotate the cam in the opposite direction to the desired setpoint.
7. Shut down the burner, and then restart. Repeat several times to be sure the low-fire setting is suitable for correct burner lightoff. Readjust, if necessary.
8. Disconnect power and reconnect the controller leadwire removed in step 3.
9. Replace the wiring compartment cover.

### Adjust Auxiliary Switch (If Used)

The auxiliary switch can be adjusted to operate at any point in the actuator stroke. After installing the switch in the actuator, turn the adjustment screw (Fig. 2) clockwise  to cause the switch to operate earlier in the stroke or turn counterclockwise  to cause the switch to operate later in the stroke.

NOTE: The proof-of-closure switch is not adjustable.

### Adjust Max Flow Limit Switch (Fig. 2)

The Max Flow Limit Switch is adjustable throughout the actuator stroke. With the switch installed in the actuator, turn the adjusting screw clockwise  to cause the switch to operate earlier in the stroke (less flow) or counterclockwise  to cause the switch to operate later in the stroke (more flow).

## OPERATION

To function as intended, the V4062 must be connected to a properly sized valve. Too large a valve will not properly control the gas flow.

When the actuator is energized, it drives to the adjustable low-fire position. Depending on the demand of the controller, the valve remains at low-fire or moves to the high-fire position. When the firing rate controller calls for no heat, the actuator returns the valve to the low-fire position. When power to the actuator is interrupted, the valve completely closes.

Fig. 4 shows the V4062 in a typical flame safeguard control system.

## SERVICE AND CHECKOUT

### CAUTION

**Equipment Damage Hazard.**  
**Unskilled technicians can damage the equipment.**  
 Only experienced, trained flame safeguard control service technicians should service or replace this control.

### Service

The actuator is not field repairable, except for replacing the auxiliary switch or valve-closed indication switch. See Installation section for procedure. Do not disassemble the valve actuator. If the actuator should fail to operate properly, replace it.

### Checkout

After the installation is complete, cycle the valve several times with the manual fuel shutoff cock closed before testing the system in actual operation.

## V4062A1156 Fluid Power Gas Actuator

The V4062A1156 Fluid Power Gas Valve Actuator was modified to provide modulation between high-and low-fire positions when used with a Series 60 controller, such as the W964 Aquatrol™ System and two auxiliary relays.

The V4062A1156 will not operate properly wired similarly to other V4062 models. See Fig. 7 for suggested wiring procedure.

### Ratings:

Voltage: 120V, 60 Hz.  
 Nominal Opening Time: 26 seconds.  
 Closing Time: one second maximum.

See Specifications section for further specifications.

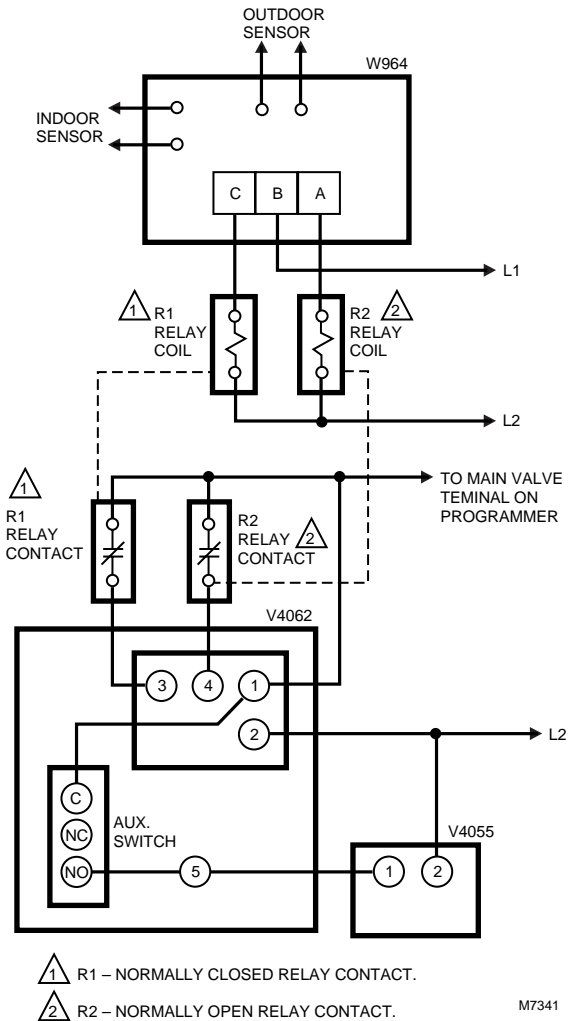

Fig. 7. Suggested wiring diagram.

**Honeywell**

**Home and Building Control**  
 Honeywell  
 1985 Douglas Drive North  
 Golden Valley, MN 55422

**Home and Building Control**  
 Honeywell Limited-Honeywell Limitée  
 35 Dynamic Drive  
 Scarborough, Ontario  
 M1V 4Z9

**Honeywell Asia Pacific Inc.**  
 Room 3213-3225  
 Sun Hung Kai Centre  
 No. 30 Harbour Road  
 Wanchai  
 Hong Kong

**Honeywell Europe S.A.**  
 3 Avenue du Bourget  
 1140 Brussels  
 Belgium

**Honeywell Latin American Region**  
 480 Sawgrass Corporate Parkway  
 Suite 200  
 Sunrise FL 33325

