

EngA®

ENGINEERED AIR®

**INSTALLATION, OPERATION
AND MAINTENANCE MANUAL**

FOR

XES-SC SERIES

**INDOOR INDIRECT GAS FIRED
SEPARATED COMBUSTION HEATING UNIT**



Intertek



Intertek

UNIT MODEL NO. _____
UNIT SERIAL NO. _____
SERVICED BY: _____
TEL. NO: _____

**CANADIAN
HEAD OFFICE
AND FACTORY**

1401 HASTINGS CRES. SE
CALGARY, ALBERTA
T2G 4C8
Ph: (403) 287-4774
Fx: 888-364-2727

**USA
HEAD OFFICE
AND FACTORY**

32050 W. 83rd STREET
DESOTO, KANSAS
66018
Ph: (913) 583-3181
Fx: (913) 583-1406

**CANADIAN
FACTORY**

6130 97th STREET
EDMONTON, ALBERTA
T6E 3J4
Ph: (780) 430-0310
Fx: (780) 434-6272

SALES OFFICES ACROSS CANADA AND USA

Retain instructions with unit and maintain in a legible condition.
Please give model number and serial number when contacting
factory for information and/or parts.

www.engineeredair.com

TABLE OF CONTENTS

YOU HAVE RESPONSIBILITIES TOO.....	3
INTRODUCTION.....	3
WARRANTY.....	5
PARTS.....	6
RECEIVING.....	6
TEMPORARY STORAGE.....	6
INSTALLATION.....	7
CODES.....	7
MINIMUM CLEARANCE FOR SERVICE AND TO COMBUSTIBLES.....	8
MOUNTING.....	9
SHIPPING MATERIALS.....	9
SUITABLE LOCATIONS.....	9
ASSEMBLY OF TWO PIECE XEs.....	9
SEPARATED COMBUSTION.....	10
COMBUSTION AIR DUCT.....	11
VENTING PRODUCTS OF COMBUSTION.....	12
NATURAL GAS AND PROPANE INSTALLATION.....	15
GAS LINE TESTING (EXTERNAL TO THE UNIT).....	15
ELECTRICAL INSTALLATION.....	15
SPLIT UNIT WIRING.....	16
Recommended 24V Field Wiring Size:.....	17
DUCT MOUNTED TE-6000-EA3 TEMPERATURE SENSOR.....	18
BEFORE START-UP.....	18
START-UP CHECK LIST.....	18
OPERATION.....	20
COMBUSTION AND FINAL UNIT CHECK FOR UNITS WITHOUT TRAC CONTROLS.....	20
UNIT SHUT-DOWN INSTRUCTIONS.....	21
Service Shut Down.....	21
MAINTENANCE.....	22
ELECTRICAL.....	22
OPERATING INSTRUCTIONS.....	22
BELT ADJUSTMENT.....	23
SET SCREWS.....	23
BEARING SETSCREW TORQUES.....	23
FAN LUBRICATION.....	24
MOTOR LUBRICATION.....	24
INSPECTION AND CLEANING.....	24
FILTERS.....	24
CONTROLS.....	24
OUTDOOR AIR INTAKES, MIXING SECTIONS AND DAMPERS.....	25
SAFETY SHUTOFF VALVE LEAK TEST:.....	25
TROUBLESHOOTING.....	26
START-UP RECORD.....	27

© Airtex Manufacturing Partnership. All rights reserved.

YOU HAVE RESPONSIBILITIES TOO

This installation, operation and maintenance manual cannot cover every possibility, situation or eventuality. Regular service, cleaning and maintaining the equipment is necessary. If you are not capable of performing these tasks, hire a qualified service specialist. Failure to perform these duties can cause property damage and/or harm to the building occupants and will void the manufacturers' warranty.

INTRODUCTION

Engineered Air units are high quality products designed and manufactured to provide many years of trouble-free operation. Engineered Air recommends that this manual be read thoroughly to ensure proper installation, efficient operation and proper maintenance of this equipment. The submittal record is considered to be part of the Installation, Operation and Maintenance Manual. Please report any omissions to the national service manager.

SAFETY PRECAUTIONS

Read, understand and follow the complete manual before beginning the installation, including all safety precautions and warnings.



FIRE OR EXPLOSION HAZARD

Failure to follow safety warnings exactly could result in serious injury, death or property damage.

Be sure to read and understand the installation, operation and service instructions in this manual.

Improper installation, adjustment, alteration, service or maintenance can cause serious injury, death or property damage.

— **Do not store or use gasoline or other flammable vapors and liquids in the vicinity of this or any other appliance.**

— WHAT TO DO IF YOU SMELL GAS

- **Do not try to light any appliance.**
 - **Do not touch any electrical switch; do not use any phone in your building.**
 - **Leave the building immediately.**
 - **Immediately call your gas supplier from a phone remote from the building. Follow the gas supplier's instructions.**
 - **If you cannot reach your gas supplier, call the fire department.**
- **Installation and service must be performed by a qualified installer, service agency or the gas supplier.**

Warning:

Pool, laundry and common cleaning products often contain fluorine or chlorine compounds. When these chemicals pass through the heater, they can form strong acids. The acid can eat through the heat exchanger wall, causing serious damage and presenting a possible threat of flue gas spillage into the building.

Warning:

This unit is connected to high voltages. Electrical shock or death could occur if instructions are not followed. This equipment contains moving parts that can start unexpectedly. Injury or death could occur if instructions are not followed. All work should be performed by a qualified technician. Always disconnect and lock out power before servicing. **DO NOT** bypass any interlock or safety switches under any circumstances.

WARRANTY

LIMITED WARRANTY

ENGINEERED AIR will furnish without charge, F.O.B. factory, freight collect, replacement parts for, or repairs to products covered herein which prove defective in material or workmanship under normal and proper use for a period of twelve (12) months from the initial start-up or eighteen (18) months from the date of shipment, whichever expires sooner, provided the customer gives ENGINEERED AIR written notice of such defects within such time periods and provided that inspection by ENGINEERED AIR establishes the validity of the claim and all pertinent invoices have been paid in full. The repairs or replacements will be made only when the complete product(s) or part(s) claimed to be defective are returned to ENGINEERED AIR or a depot designated by ENGINEERED AIR, transportation charges prepaid. Repairs or replacements as provided for by this paragraph shall constitute fulfillment of all ENGINEERED AIR's obligations with respect to this warranty. The refrigerant charge is not included in any part of this warranty. This warranty does not apply to any products or parts thereof that have been subject to accident, misuse or unauthorized alterations, or where ENGINEERED AIR's installation and service requirements have not been met.

The foregoing warranty is in lieu of all other warranties, express or implied. ENGINEERED AIR specifically disclaims any implied warranty of merchantability and/or fitness for purpose. Under no circumstances shall ENGINEERED AIR be liable to, nor be required to indemnify, Buyer or any third parties for any claims, losses, labour, expenses or damages (including special, indirect, incidental, or consequential damages) of any kind, resulting from the performance (or lack thereof) of this Agreement or the use of, or inability to use the goods sold hereunder, including, but not limited to, damages for delay, temporary heating/cooling costs, loss of goodwill, loss of profits or loss of use. Furthermore, the parties agree that the Buyer's sole remedy under this Agreement shall be limited to the limited warranty set forth in the preceding paragraph relating to the repair or replacement of any defective goods. Under no circumstances shall any claim or award against ENGINEERED AIR exceed the original contract price whether awarded through arbitration, litigation or otherwise.

ENGINEERED AIR Warranty is void if:

1. The unit is not installed in accordance with this manual.
2. The start-up and operation of the unit is not performed in accordance with this manual.
3. The unit is operated in an atmosphere containing corrosive substances.
4. The unit is allowed to operate during building construction.
5. The unit is allowed to operate in atmospheres where chlorine or chlorine compounds are present or which contain any contaminant (silicone, aluminum oxide etc.) that adheres to the spark ignition flame sensing probe.

PARTS

WARNING: Any replacement part must be of equivalent listing or certification and be functionally equivalent. The replacement part must meet the original's specification in terms of functionality including certifications, timing, input and output range, accuracy and operation.

 Failure to replace parts or components with equivalent parts can cause property damage, injury or death.

1. Motors:
Motor manufacturers have service centers that will repair or replace motors as required.
2. Parts Other Than Motors:
Contact the nearest Engineered Air sales office or factory. Be sure to include Model Number, Serial Number, date of installation and nature of failure along with the description of the parts required. Some parts may not be stocked items that must be made or ordered.

RECEIVING

Refer to the back of the packing slip for receiving unit instructions.

On receipt of the unit, check for damage. Inspect protective covers for punctures or other signs that there may be internal damage. Remove protective covers and check for internal damage. Replace covers if the unit is not being assembled or installed at this time. Open access doors and check for internal damage. Close access doors when the inspection is complete.

All units are pre-tested at the factory immediately prior to shipping and are ensured to be in good operating condition at that time. If damage is found follow the instructions on the packing slip.

On receipt of the unit, check electrical characteristics (see rating plate) to make sure the unit voltage is compatible with that available for the unit. All parts for field installation are listed on the shipping order form.

TEMPORARY STORAGE

If a unit is to be stored prior to installation the following precautions are required:

- Store in a well drained area that will not accumulate surface water.
- Store in an area where the unit will not get damaged.
- The entire perimeter and any full height cross members of the unit must be supported by a level surface and the supporting surface must be adequate for supporting the entire weight of the unit.
- All protective coverings that were provided for shipping must be in place.
- Protect from rain and snow.

INSTALLATION

Warning:

This unit is not rated for hazardous locations and cannot be installed in areas requiring any hazardous location rating.

Caution:

All wiring, piping and fuel line installation must be completed by qualified persons in accordance with all federal, state, provincial and/or local codes.

Note: Installation shall be in accordance with this manual and all other associated component and control Installation, Operation and Maintenance Manuals.

CODES

In Canada:

1. The installation of this unit shall be in accordance with the latest edition of the Canadian Electrical Code, Part 1 – C.S.A. Standard C22.1, Provincial and Local Codes, and in accordance with the local authorities having jurisdiction.
2. This unit shall be electrically grounded in accordance with the latest edition of the Canadian Electrical Code, Part 1 – C.S.A. Standard C22.1, Provincial and Local Codes, and in accordance with the local authorities having jurisdiction.
3. The installation of this unit shall be in accordance with the latest edition of the Canadian Natural Gas and Propane Installation Code, C.S.A. Standard B149.1, Provincial and Local Codes, and in accordance with the local authorities having jurisdiction.
4. In accordance with local authorities having jurisdiction or CSA. Standard B149.1 a readily accessible approved manual shut-off valve shall be installed in either the drop or riser as close as possible to the valve train (gas manifold).
5. The installation of this unit shall be in accordance with the latest edition of the National Plumbing Code of Canada, Provincial and Local Codes, and in accordance with the local authorities having jurisdiction.
6. The installation of this unit shall be in accordance with all other National, Provincial and Local Codes, and in accordance with the local authorities having jurisdiction.

In USA:

1. The installation of this unit shall be in accordance with the latest edition of the National Electrical Code (ANSI/NFPA 70), State and Local Codes and in accordance with the local authorities having jurisdiction.
2. This unit shall be electrically grounded in accordance with the latest edition of the National Electrical Code (ANSI/NFPA 70), State and Local Codes and in accordance with the local authorities having jurisdiction.
3. If the unit has not been provided with an electric disconnect switch, one of adequate ampacity shall be installed in accordance with Article 430 of the National Electrical Code (ANSI/NFPA 70).
4. The installation of this unit shall be in accordance with the latest edition of the National Fuel Gas Code ANSI/Z223.1/NFPA 54, State and Local Codes and in accordance with the local authorities having jurisdiction.
5. In accordance with local authorities having jurisdiction or NFPA 54 an accessible approved manual shutoff valve shall be installed within 6 ft (1.8 m) of the valve train (gas manifold).
6. The installation of this unit shall be in accordance with the latest edition of the National Standard Plumbing Code (NSPC), State and Local Codes and in accordance with the local authorities having jurisdiction.
7. The installation of this unit shall be in accordance with all other National, State and Local Codes, and in accordance with the local authorities having jurisdiction.

MINIMUM CLEARANCE FOR SERVICE AND TO COMBUSTIBLES

For Safety and Service, the following minimum clearances on the units shall be observed, in inches (mm):

Heaters must be installed to meet at least the minimum clearances shown on the rating plate. The rating plate is located in the burner compartment. Be sure to allow enough clearance in front of the unit for removing the burners and above for removing fan motors and blades.

MODEL	COMBUSTIBLE CLEARANCE						SERVICE CLEARANCE	
	TOP	FRONT	BACK	SIDE	BOTTOM	FLUE	SERVICE/ BURNER SIDE	CONTROL PANEL P
XES	1" (25)	6" (152)	0	0	C‡	6" (152)	24" (610)	42" (1068)

P - As required by the Canadian Electrical Code or the National Electrical Code.

* - Service Clearance For Burner & Blower Access, 24" (610).

‡ - XES with suffix CF on combustible floor requires special base Part# CB(2,3,4,5,7,8, & 10).

MOUNTING

Units must be mounted level. Failure to do so can cause operational problems that can void warranty. Failure to do so can result in injury or death, damage to the equipment and/or building and can be a cause of poor indoor air quality. Equipment must be installed so that sufficient working clearance and component access is provided. Consult the Submittal Record for specific unit mounting.

SHIPPING MATERIALS

Remove shipping materials. Shipping materials may include, but are not limited to:

- Protective covers over openings, inlets etc.
- Protective covers over split sections if provided.
- Tie-down bolts, straps and blocks on fan vibration isolators.
- Indirect fired heat exchangers may be supported with wood for shipping. Remove.

SUITABLE LOCATIONS

These appliances are suitable for use in aircraft hangars, parking structures and repair garages when marked and installed, as applicable, in accordance with:

- Standard on Aircraft Hangars, ANSI/NFPA 409
- Standard for Parking Structures, ANSI/NFPA 88A
- Standard for Repair Garages, ANSI/NFPA 88B
- Installation Code for Natural Gas and Propane Installation Code, CSA B149.1

ASSEMBLY OF TWO PIECE XESs

This procedure covers the required field assembly of XES units.

HB (HIGH BOY) UNITS

- a) Place the heat section on top of the fan section so the heat section is 1/2" (13 mm) behind the fan section.
- b) Carefully slide the heat section forward until the back and sides of the heat and fan section are flush. This will lock the two pieces together at the back as the locking clip engages. Do not damage foam tape which acts as air seal between sections.
- c) Remove the fan section door, then lift the front of the heat section and block the front open about 4" (102 mm).
- d) Feed the motor wires through the grommet between the sections and allow the wire to hang in the fan compartment.
- e) Lower the heat section back onto the fan section. Check alignment of the pieces then drive sheet metal screws up from the fan section into the heat section. Holes are provided in the fan section at the front sides for locating screws. Make sure the motor wires are not pinched between sections - but feed smoothly from one section to the other.
- f) The unit is now one piece locked together at the rear by a clip and at the front by two sheet metal screws.
- g) Follow the wiring diagram on the unit to connect motor wires to motor.

- h) Inspect and test electrical components and motor operation.

CF (COUNTER FLOW) UNITS

- a) Place the fan section on top of the heat section so the fan section is 1/2" (13 mm) forward of heat section.
- b) Carefully slide the fan section back until the back and sides of the heat fan section are flush. This will lock the two pieces together at the back as the locking clip engages. Do not damage foam tape which acts as air seal between sections.
- c) Remove the outer fan door, vent pipe, shipping cardboard and inner fan door. Drive sheet metal screws from the fan section into the heat section. Holes are provided in the front vestibule at sides for locating two sheet metal screws.
- d) The unit is now one piece locked together at back by clip and at front by two sheet metal screws.
- e) Motor wires and upper limit control wires are clipped at top of heat section. Feed both of these wire pairs into the fan compartment, through the hole provided. Wires should be neatly clipped in place and taut so they will not contact the hot draft hood parts.
- f) Connect the motor wires to the motor and upper limit control wires to the limit as shown on wiring diagram.
- g) Install the inner fan door.
- h) Connect the vent pipe between the heat section and the top collar of the fan section. The vent connector piece should be secure and located at the top of the fan section.
- i) Inspect and test the electrical components and motor operation.

SEPARATED COMBUSTION

Warning: 	Separated combustion equipment is not designed or approved for use in atmospheres containing flammable or chlorine vapors.
--	---

Warning: 	The installation of separated combustion systems must be completed by qualified persons in accordance with all federal, state, provincial and/or local codes.
--	--

Warning: 	Do not operate this heater without all combustion air and flue gas piping installed.
--	---

The heater shall not be connected to a venting system serving any other gas, liquid or solid fuel fired appliance. Installation shall be in accordance with the requirements of authorities having jurisdiction and ANSI Z2231/NFPA 54 or CSA B149.1. The vent shall be installed in such a manner that access to the appliance or unit rating plate is not obstructed.

Table I indicates the maximum equivalent length of the various sizes of vent and combustion air for each furnace model. Equivalent length equals the total length of straight pipe, plus the values for the fittings as shown in the Table II below.

Table I
Maximum Equivalent Feet

	Vent Diameter (inches)				Combustion Air Diameter (inches)				
	3	4	5	6	4	5	6	7	8
XES65	150	-	-	-	100	150	-	-	-
XES100	75	150	-	-	25	125	150	-	-
XES130	50	150	-	-	25	100	150	-	-
XES160	25	150	-	-	-	50	125	150	-
XES225	-	100	150	-	-	25	100	150	-
XES255	-	50	150	-	-	-	50	150	-
XES320	-	25	125	150	-	-	25	100	150

Table II

Equivalent length (feet) of vent or combustion air fittings								
Fittings	Vent or Combustion Air Diameter (inches)							
	3	4	5	6	7	8	9	10
Tee	8	11	14	15	18	21	23	26
90°	5	7	9	10	12	14	15	17
45°	3	4	5	5	6	7	8	9

Example: System Pipe Size = 5"
 2 – 90° Elbows (5") = 2 x 9 = 18 ft.
 5 - 4 ft. Lengths of 5" = 20 Ft.
 Total Equivalent Feet = 18 ft. + 20 ft. = 38 ft.

This manual describes two options for separated combustion systems:

- Side Wall Vent
- Vertical Vent

COMBUSTION AIR DUCT

Each separated combustion XES heater shall be equipped with its own combustion air supply. It must not connect to any other air intake systems.

Use single wall pipe constructed of minimum 24ga galvanized steel or a material of equal durability and corrosion resistance.

Single wall combustion air duct may be externally insulated, as required.

Each slip joint shall be secured with corrosion resistant screws or rivets, and sealed with an adhesive silicon sealant and/or aluminum tape.

For horizontal combustion air systems longer than 5 ft (1.5m) the piping must be supported every 3 ft (1m).

VENTING PRODUCTS OF COMBUSTION

Each heater must have its own vent system, and must not be connected to other venting systems or chimney.

Use 'C' Vent. All joints must be secured with corrosion resistant screws or rivet, and sealed with sealant and/or aluminum tape rated to 500°F (290°C).

<p>Warning:</p> 	<p>Do not use PVC, ABS or any other non-metallic pipe for venting.</p>
--	---

Any run of single wall vent pipe passing through an unheated space should be insulated with insulation rated for at least 550°F (280°C) to prevent condensing. In cases where condensing is expected, install a Tee at the bottom of the vertical section, with a drain for condensate.

Horizontal lengths of the vent system must be installed and sloped ¼" per foot (2%) to prevent the accumulation of condensate.

Maintain a minimum of 6" (150mm) clearance from any combustible material.

Do not install dampers or other restrictive devices in the flue vent pipe.

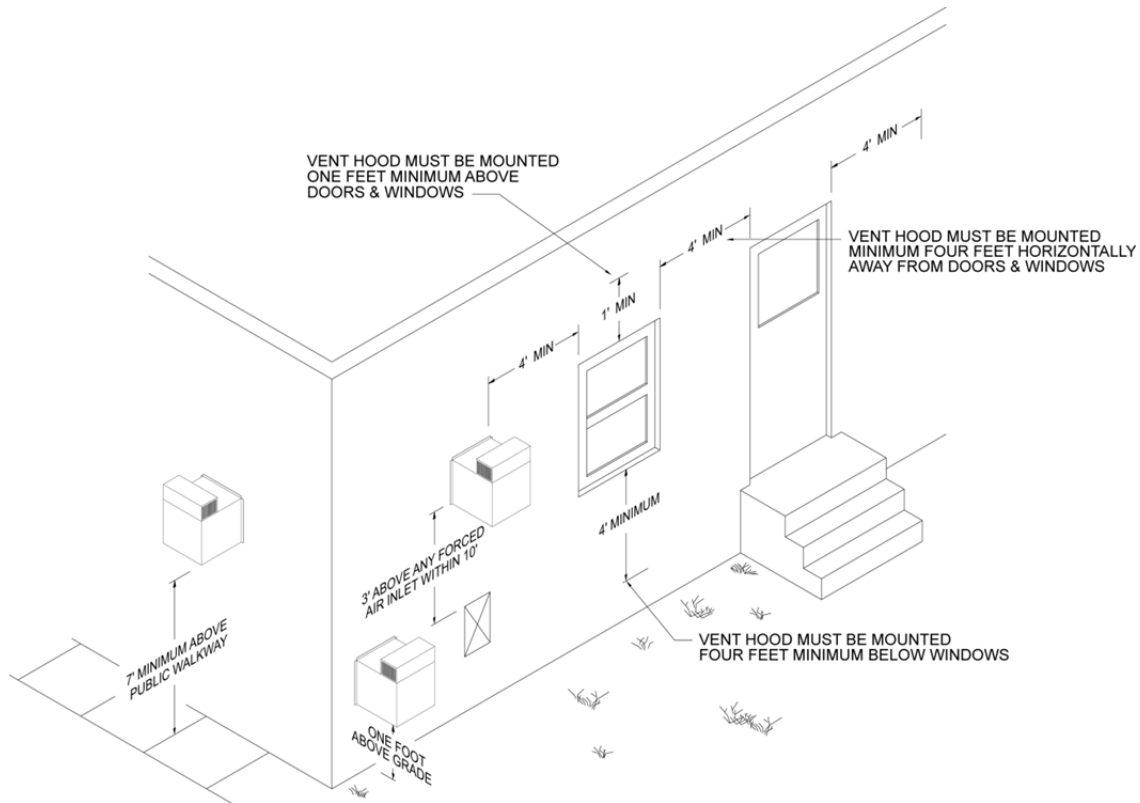

Side Wall Vent

Only Engineered Air supplied through-wall concentric vent terminations are approved for use with XES furnace models.

Refer to the sketch below.

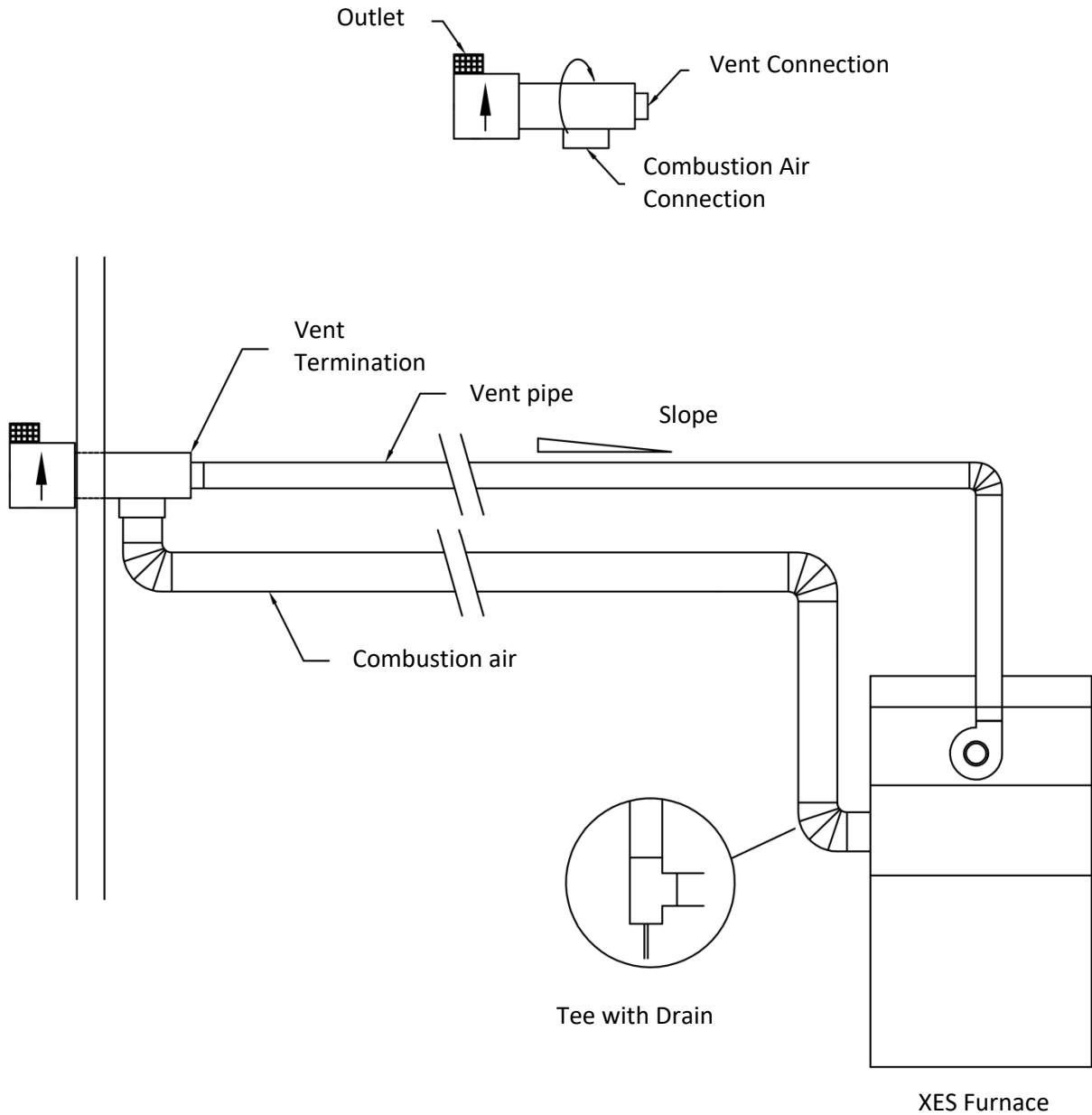

Vertical Vent

An approved vent cap (eg. Breidert), furnished by the customer, must be installed at the termination point of the vertical vent system. The vent in this arrangement is category 1. 'B' Vent is acceptable. Installer may seal joints as required.

Refer to the sketch below.

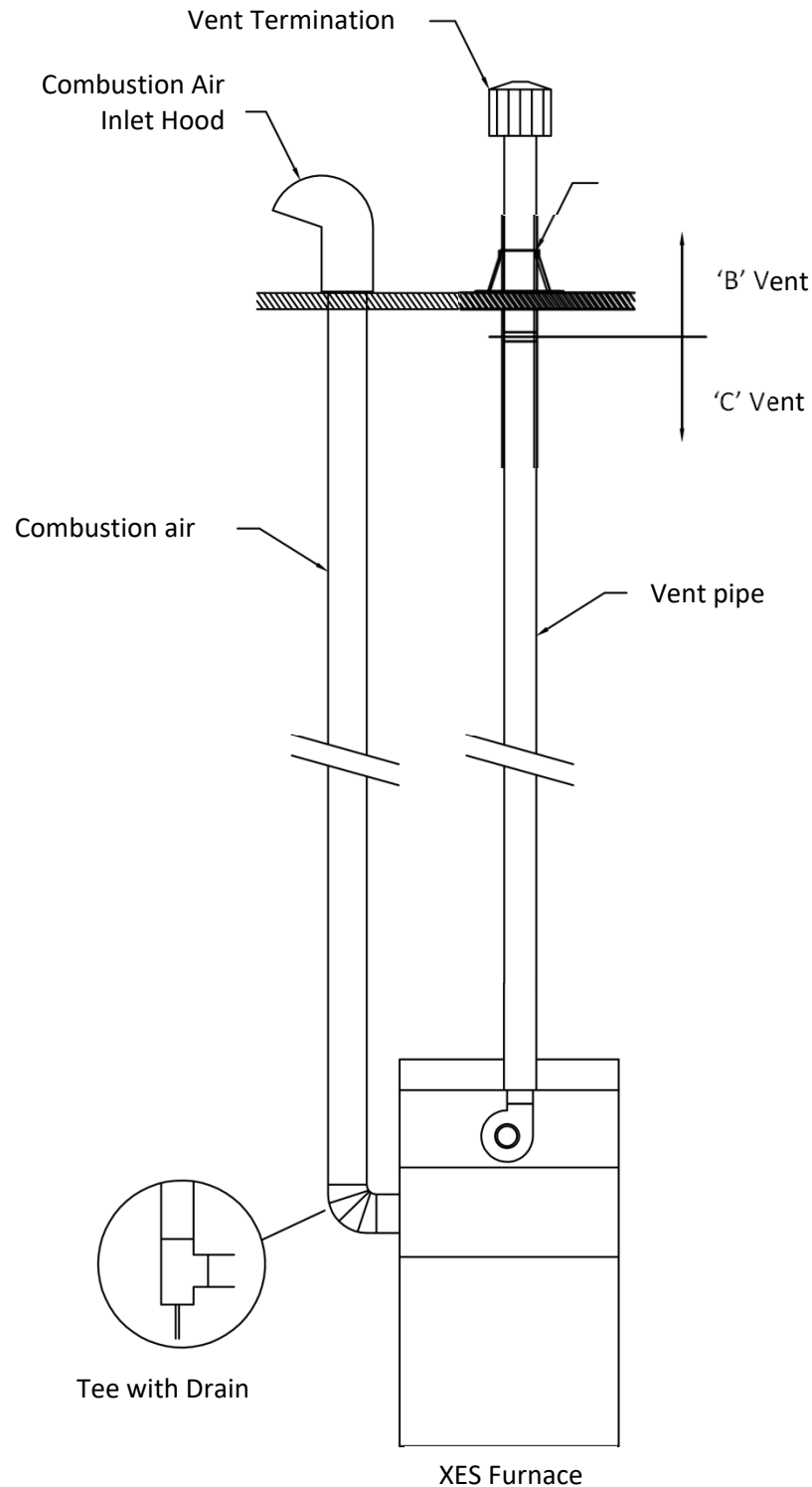

NATURAL GAS AND PROPANE INSTALLATION

1. Installation must be made in accordance with the requirements of the authorities having jurisdiction.
2. Check the unit rating plate and confirm fuel type, supply pressure, input rating and temperature rise.
3. Refer to the heater rating plate for determining the minimum gas supply pressure for obtaining the maximum gas capacity for which this heater is specified.
4. Gas supply pressure higher than the unit rating plate requires an additional field supplied gas regulator.
5. Install an approved appliance shutoff valve on the gas supply in accordance with the requirements of the authorities having jurisdiction.
6. Gas lines shall not interfere with unit access. The gas line connection at the heater shall have an approved drip leg with screwed cap.
7. A minimum 1/8 inch NPT plugged tapping, accessible for test gauge connection, must be installed immediately upstream of the gas supply connection to the unit.

GAS LINE TESTING (EXTERNAL TO THE UNIT)

The appliance and its individual shutoff valve must be disconnected from the gas supply piping system during any testing of that system at test pressures in excess of 0.5 psi (3.5 kPa).

The appliance must be isolated from the gas supply system by closing its individual shutoff valve during any testing of that system at test pressure equal to or less than 0.5 psi (3.5 kPa).

ELECTRICAL INSTALLATION

Do not install anything that will interfere with equipment access or the rating plate.

All penetrations through the unit walls must be caulked and sealed to prevent air from entering the unit.

The unit must be electrically grounded and all wiring must be installed in accordance with the National Electrical Code, ANSI/NFPA 70, and/or the Canadian Electric Code CSA 22-1 and to the approval of the authorities having jurisdiction. Field wiring diagrams, internal wiring diagrams and operating functions are included in the control cabinet. The power requirements are indicated on the rating plate. Where field wiring of control circuits is required, take care to size the field wiring for a maximum 10% voltage drop. The control circuit ampacity is noted on the field wiring diagram. See the field wiring diagram for requirements for shielded or twisted pair wire for solid state devices.

All wiring shall be installed according to the requirements of the authorities having jurisdiction. Field wiring, internal wiring diagrams and unit operating functions are included in the control cabinet of the unit. The power requirements are indicated on the rating plate.

SPLIT UNIT WIRING

All split wiring must be completed by an electrician prior to starting the equipment. A number of different methods are used to reconnect the wiring.

Power wire: this wiring is generally not broken or spliced, and will extend from the device back to the contactor or terminal block inside the electrical panel(s). The wire will be tagged to identify which panel it extends to and will be numbered to the corresponding connection.

The location of the equipment split line may result in the wire being disconnected at the device it is feeding. The wire bundle will be tagged and identified. Confirm correct rotation of 3 phase devices after the wiring connections has been completed.

Control wire: this wire is typically broken near the split line, to be reconnected at either a enclosed terminal block, junction box or extended to a nearby control panel. Each wire or wire bundle will be tagged and numbered to indicate the location it is sent to.

Sensor wire shield: The drain wire from the shield must be grounded (at one end only). A ground connection point is available for connection at the point of termination.

All loose wiring must be securely fastened to the equipment casing upon completion.

Caution: 	Temporary Power Generation The warranty will be void if the voltage being fed from any temporary generator is not within 10% of the nominal rated nameplate voltage and voltage imbalance shall be limited to 2%. A power monitor shall be installed by others to properly monitor power quality and conditions. All generator sets shall be provided with overcurrent and earth-fault protection. The protective apparatus should be capable of interrupting, without damage, any short-circuit current that may occur.
--	---

Warning: 	No unspecified external load shall be added to the control transformer circuit(s) or to the main power circuit(s).
--	---

Recommended 24V Field Wiring Size:

Copper conductors only

Circuit Load (Amps) (1)	Maximum Total Length of Run									
	< 50 Ft (~ 15 m)	< 100 Ft (~ 30 m)	< 150 Ft (~ 45 m)	< 200 Ft (~ 60 m)	< 250 Ft (~ 75 m)	< 300 Ft (~ 90 m)	< 350 Ft (~ 105 m)	< 400 Ft (~ 120 m)	< 450 Ft (~ 135 m)	< 500 Ft (~ 150 m)
1	16 AWG	16 AWG	16 AWG	16 AWG	16 AWG	16 AWG	14 AWG	14 AWG	14 AWG	12 AWG
2	16 AWG	16 AWG	16 AWG	14 AWG	12 AWG	12 AWG	12 AWG	10 AWG	10 AWG	10 AWG
3	16 AWG	16 AWG	14 AWG	12 AWG	12 AWG	10 AWG	10 AWG	10 AWG		
4	16 AWG	14 AWG	12 AWG	10 AWG	10 AWG	10 AWG				
5	16 AWG	12 AWG	12 AWG	10 AWG						
6	16 AWG	12 AWG	10 AWG	10 AWG						
7	14 AWG	12 AWG	10 AWG							
8	14 AWG	10 AWG	10 AWG							
9	14 AWG	10 AWG								
10	12 AWG	10 AWG								
11	12 AWG	10 AWG								
12	12 AWG	10 AWG								
13	12 AWG									
14	12 AWG									
15	12 AWG									

Notes:

- 1) The field wiring load depends on the actual load on a particular control circuit the field wiring is connected to. Refer to the internal wiring diagram of the unit.
- 2) The table above is based on a maximum 10% voltage drop on a 24V control circuit. Wire size was calculated using the following formula:

$$CM = (25 \times I \times L) / V$$

Where **CM** is circular mils of conductor for a constant load of **I** amps, wire length **L** in feet from the unit to the field device and back, and voltage drop **V**.

When connecting to a three phase power supply, check for the correct rotation of all motors and fans. If the rotation is incorrect, reverse the rotation at the incoming power only. All electrical conduit outlets in the control panel must be sealed to prevent moist building air from migrating to the control panel.

DO NOT install any devices in a manner that interfere with access to the rating plate or door opening.

Replacement wiring must be equivalent to original wire. See field wiring diagram for requirements for shielded or twisted pair wire for solid state devices.

DUCT MOUNTED TE-6000-EA3 TEMPERATURE SENSOR

Some applications require field installed discharge air sensors.

The sensor strip must be parallel to the air flow. The sensor should be mounted near the center of a straight duct 5 to 10 feet (1500 to 3000mm) downstream of the supply air connection to the Engineered Air unit. Avoid installing near duct transitions or elbows.

Use twisted pair or shielded wiring. The ground shield should be grounded only at the unit control panel end. Protect the opposite end ground and any unused wire with electrical tape.

When installing an Engineered Air TE-6000-EA3 duct mounted temperature sensor, the sensor strip must be parallel to the air flow as shown.

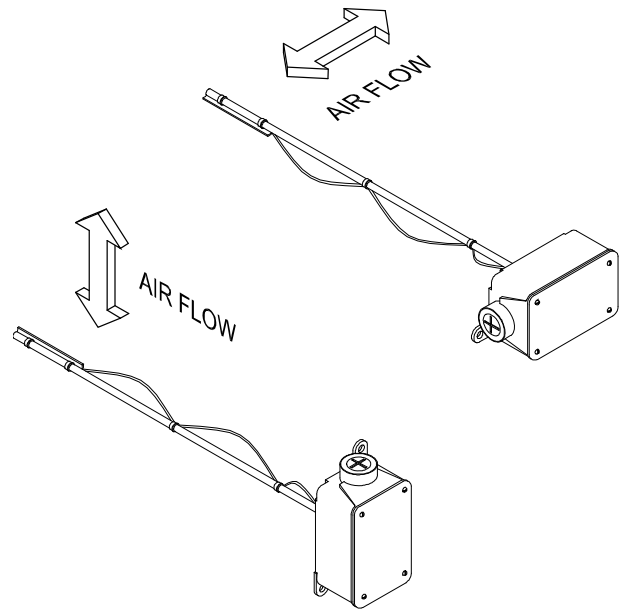

BEFORE START-UP

Ensure all shipping blocks, tie-down bolts, straps and blocks, etc. are removed.

Perform a Safety Shutoff Valve Leak Test as described in this manual.

START-UP CHECK LIST

Warning:	This unit is connected to high voltages. Electrical shock or death could occur if instructions are not followed. This equipment contains moving parts that can start unexpectedly. Injury or death could occur if instructions are not followed. All work should be performed by a qualified technician. Always disconnect and lock out power before servicing. DO NOT bypass any interlock or safety switches under any circumstances.
-----------------	--



The start-up and operation must be done in accordance with safe practices. Start-up must be performed by qualified personnel. Complete the attached start-up record.

- 1 Set all associated electrical switches, controls, thermostats and main disconnect switch to "OFF" position.
- 2 Close all manual valves and field piping valves.
- 3 Confirm that all shipping materials have been removed. See any supplemental instructions shipped with the unit to help identify possible locations.
- 4 Check all bearings, drive and fan set screws for tightness.
- 5 Check drive alignment and belt tension. Refer to Maintenance section.

- 6 Turn disconnect switch ON (control switch is still off) and check the supply voltage. Voltage must be within 10% of rating plate. If not, contact the installing electrical contractor and have the voltage condition corrected before continuing start-up.
- 7 Check all fan motors for correct rotation. If incorrect, reverse rotation on incoming power only.
- 8 Set thermostat or controller to the "OFF" position and turn unit control switch "ON".
- 9 Check the amperage draw of the motor. Refer to unit or motor rating plate for full load amps. At the unit, check and record the voltage while it is running. For 3 phase power the phase to phase voltage imbalance should be less than 2%. A 2% voltage imbalance can cause up to a 10% current imbalance that will overheat motor windings.

To calculate voltage imbalance (NEMA method) refer to the following example:

Phase to phase voltage readings: 235V 236V 230V
The average Voltage between legs is $233.7V (235+236+230)/3$
Highest voltage deviation from average is: $233.7V - 230V = 3.7V$
Voltage imbalance percentage = Highest deviation divided by average X 100

$3.7 / 233.7 \times 100 = 1.6\%$ This imbalance is less than 2% and therefore is OK

If voltage imbalance is greater than two percent (2%), turn off main disconnect and contact the installing electrical contractor to have the voltage condition corrected.

- 10 Purge all the air from the gas lines. Refer to the Canadian Natural Gas and Propane Installation Code, C.S.A. Standard B149.1 or the National Fuel Gas Code ANSI/Z223.1/NFPA 54 for proper method. Check all connections for leaks and correct. Ensure that the inlet pressure agrees with the approval label.
- 11 Enable heating; refer to unit function for correct sequence and operation.
- 12 Confirm field wiring voltage drop is less than 10% when equipment is operating.
- 13 For the unit to operate properly a system air balance must be performed to ensure correct air flow. Failure to do so can damage the equipment and/or building and can be a cause of poor indoor air quality.
- 14 Damper sections (optional):
 - i. Flat mixing dampers:

Both the fresh air and return air dampers are fully open when the dampers are at a 45° angle when fully stroked. This provides optimum mixing of the air streams for this damper arrangement.
 - ii. Angle mixing damper:

Angle mixing section dampers open to an angle of 90° when fully stroked. This provides optimum mixing of the air streams for this damper arrangement.
- 15 **Set all controls to the settings indicated on the wiring diagram.**
- 16 Re-install all access panels.
- 17 Remove any packing material or debris and dispose appropriately.

OPERATION

Warning:

This unit is connected to high voltages. Electrical shock or death could occur if instructions are not followed. This equipment contains moving parts that can start unexpectedly. Injury or death could occur if instructions are not followed. All work should be performed by a qualified technician. Always disconnect and lock out power before servicing. **DO NOT** bypass any interlock or safety switches under any circumstances.

Warning:

Proper commissioning and start-up of the air handling system is the responsibility of the installing contractor. It is recommended that an air balance be completed by a certified air balancing contractor to insure the air volume being delivered matches the unit rating plate. Failure to perform a proper air balance can cause injury or death, damage to the equipment, property damage, system operational problems, or be a cause of poor air quality. Moisture carry over can result from improper air flow.

This unit may incorporate one or more functions and a variety of controls and options to suit individual requirements. A description of the unit functions and options is shown on the Electrical Data Sheet and unit wiring diagram. Carefully check your wiring diagram to verify that all remote controls are properly located and correctly field wired.

Some equipment may contain programmable unitary controllers or programmable logic controllers (PLC). Additional information can be obtained from the specific programmable control manufacturer. Often this information is available from the control manufacturer's website.

COMBUSTION AND FINAL UNIT CHECK FOR UNITS WITHOUT TRAC CONTROLS

The heater has been test fired in the factory for firing rate and combustion. Field conditions may require small adjustments to be made. These checks should be done by a qualified service man.

1. When the main flame is established, check the gas manifold pressure at the test point nearest the burner with the unit operating at high fire. Check the name plate for the correct manifold pressure and adjust the appliance regulator if necessary. The unit inlet gas pressure should not go below the minimum pressure shown on the nameplate when at high fire. Ensure that the temperature rise does not exceed nameplate.
2. Check CO and O₂ reading at maximum and minimum inputs shown on name plate. CO should generally not be above 200 ppm and a very maximum of 300 ppm. O₂ reading should range from 4% to 7% at high fire on all units. Low fire combustion values are found on the table below for units that have constant combustion air or variable combustion air damper.

For units X-TRAC controllers refer to Combustion Set-Up section in the Installation, Operation and Maintenance Manuals for the respective controls.

3. Check flue outlet pressure on indoor unit to make sure that it does not exceed the maximum shown on the nameplate. (See maximum overfire pressure).
4. When the unit start up is complete, re-check the amperage draw of each motor (i.e., after an air balance).
5. Ensure that the safety controls are operative, i.e., flame ignition control, high limit, etc. (See specification sheets on all controls). Recheck setting of all limits and temperature controls.

UNIT SHUT-DOWN INSTRUCTIONS

Service Shut Down

1. Set the thermostat in the "OFF" position.
2. Close the manual firing valve in the manifold on gas fired heaters or the manual oil valve on oil fired heaters.
3. If the unit was firing at the time of shut down allow the main blower to run for a sufficient period to cool off the heat exchanger.
4. Set the unit "ON-OFF" toggle switch to the "OFF" position.
5. Set the main power disconnect switch to the "OFF" position.



CAUTION: If the unit is to be off for an extended period of time, close the manual shut off valve.

MAINTENANCE

Warning:

This unit is connected to high voltages. Electrical shock or death could occur if instructions are not followed. This equipment contains moving parts that can start unexpectedly. Injury or death could occur if instructions are not followed. All work should be performed by a qualified technician. Always disconnect and lock out power before servicing. **DO NOT** bypass any interlock or safety switches under any circumstances.

To provide a maintenance history, it is recommended that the owner have a maintenance file for each unit. **The following maintenance instructions are to be carried out each spring and fall or as otherwise indicated by qualified service personnel.**

Caution:

Label all wires prior to removal when servicing controls or critical components. Wiring errors can cause improper and dangerous operation.



Verify proper operation after servicing.

Warning:

Any replacement part must be of equivalent listing or certification and be functionally equivalent. The replacement part must meet the original's specification in terms of functionality including certifications, timing, input and output range, accuracy and operation.



Failure to replace parts or components with equivalent parts can cause property damage, injury or death.

ELECTRICAL

1. Check all wiring for loose connections.
2. Check voltage at unit (while in operation).
3. Check amperage draw against unit rating plate.
4. Where possible, all contactors should be inspected to ensure that contacts are clean and are making good contact. If contacts are abnormally pitted or burned badly, replace contactor. Single phasing and motor burnouts can result from bad contacts.

OPERATING INSTRUCTIONS

Lighting, shut off and shut down instructions are provided on the rating plate located in the burner compartment.

BELT ADJUSTMENT

For maximum belt and bearing life, pulley alignment and belt tension must be properly maintained. Only replace with belts of the proper type and size.

NOTE: If belts are too tight or improperly aligned, the life expectancy of the motor(s), fan bearings and belt(s) are reduced.

Alignment: Pulleys must be aligned to within 1/16" per foot (1mm per 760mm) of span.

FOR FANS EQUIPPED WITH SPIDER BRACKETS:

A properly adjusted V-belt rides the inside of the pulley faces. Because the sides of the belt wedge in the pulleys, the V-belt does not have to be extremely tight. It should be as loose as possible without slipping in the pulley grooves.

Belt deflection: 3/4 " (19mm) for each foot (300mm) of span between the pulleys.

FOR FANS EQUIPPED WITH PILLOW BLOCK BEARINGS:

Belt Deflection: Allow 1/64" (0.4mm) of deflection for each 1" (25.4 mm) of span length.

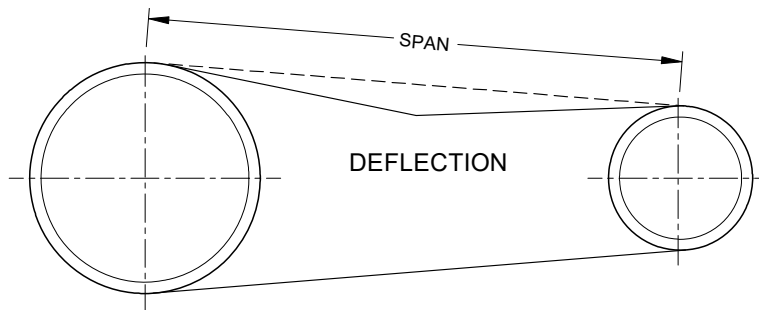

CAUTION:



OVERTIGHTENING SET SCREWS CAN DAMAGE BEARINGS.

SET SCREWS

Check set screws on fan wheel, fan bearings, fan and motor pulleys for looseness on the shaft. Tighten where required. IT IS IMPORTANT TO PERFORM THIS CHECK BEFORE INITIAL START-UP, AFTER A RUN-IN PERIOD OF 2 WEEKS AND THEN ON 4 MONTH INTERVALS.

BEARING SETSCREW TORQUES

The bearing set screw torque for shafts up to 1" (25 mm) is 35 in-lb (4.0 Nm).

FAN LUBRICATION

No lubrication of the fan bearings is necessary. Both ball and sleeve fan bearings are permanently lubricated for their life.

MOTOR LUBRICATION

Generally motor should be lubricated with a few drops of non-detergent SAE NO. 20 or SAE 30 oil once each year. **DO NOT** over-oil or use light-weight household oil.

INSPECTION AND CLEANING

Appliances should be inspected once every four months during the heating season where the equipment is operating under normal conditions. If the furnace is located where unusual amounts of dust or soot or other impurities are contained in the air, more frequent inspection is recommended.

It is good maintenance practice to thoroughly vacuum the fan compartment, fan and burner compartment at least once per year, to remove accumulated dust. The fan can be removed for cleaning.

FILTERS

Filter-changing intervals can be based on the pressure drop across the filter or by calendar scheduling or visual inspection. Scheduled intervals should be between one and six months, depending on the pollutant loading from indoor and outdoor air. More-frequent changes may be required during the economizer season.

Units that operate with high levels of outside air should have filters removed (or moved to winter filter location if available) during the winter months in areas that have heavy frost or snow.

Plugged or excessively dirty filters can cause damage to the equipment. See submittal record for filter quantities, sizes and types. Use same size and type for replacement.

1. High Velocity Permanent:
It is important that the filters be checked and cleaned regularly during the period immediately following installation, in order to determine the best service interval. To clean, rinse with water. Shake off excess water and re-install. These filters do not require an oil adhesive.
2. Pleated Throwaway and/or Replaceable Media (Cartridge, Bag):
Replacement filters can be obtained from any Engineered Air representative.

In some applications the used filters/media may contain chemical or biological hazards. All local, regional and national regulations for safety and disposal should always be followed.

CONTROLS

Annually clean and recalibrate all controls, check for proper operation, and repair or replace any faulty controls. Check all damper hardware settings every three months. Replace blown fuses with equivalent size and type fuse. Failure to do so can result in damage to the unit.

OUTDOOR AIR INTAKES, MIXING SECTIONS AND DAMPERS

Outdoor air intakes, screens, and adjacent areas shall be checked semi-annually for cleanliness, integrity and proper operation. Adjust dampers where required.

SAFETY SHUTOFF VALVE LEAK TEST:

Safety shutoff valves require a qualified technician to perform a leak (bubble) test to determine tightness of closure on a least an annual basis. A very small amount of leakage is normal. Valve leakage rates exceeding those noted in the table below require repair or valve replacement. For more detailed valve leak test instructions, refer to the valve manufacturer’s instructions.

1. De-energize the control system.
2. Close the upstream manual gas valve.
3. Connect a ¼” (6mm) tube to the outlet pressure tap on the safety shutoff valve.
4. Immerse the opposite end of the ¼” (6mm) tube (cut to a 45° angle) vertically ½” (13mm) into a clear container of water.
5. Count the number of bubbles appearing during a 10 second period.
6. If the bubble rate is greater than that noted in the table repair or replace the valve.
7. If bubble rate is less than noted in the table, remove the ¼” (6mm) tube, reconnect the outlet pressure tap plug.
8. Energize the control system and open upstream manual gas valve.
9. After testing check all piping connections and plugs for external leakage.

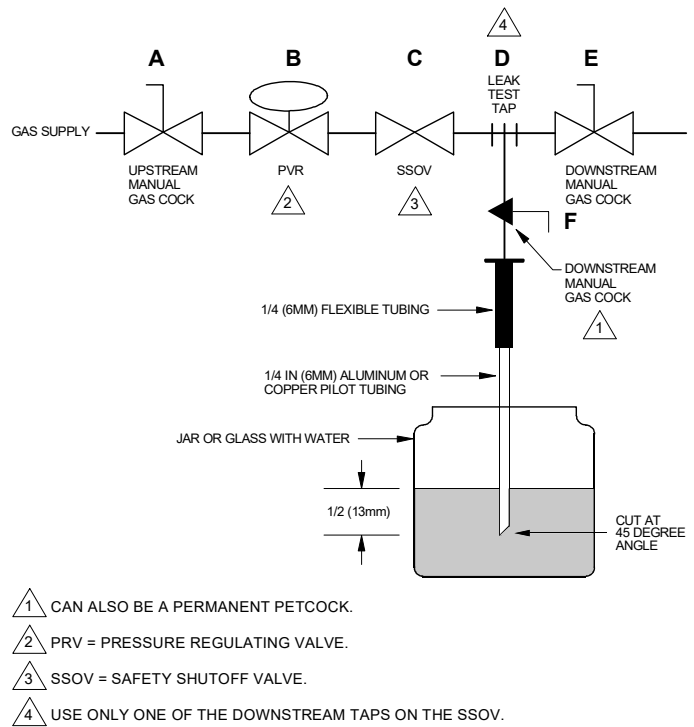

The maximum leakage rate (bubbles/10sec.) is 6.

TROUBLESHOOTING

Warning:

This unit is connected to high voltages. Electrical shock or death could occur if instructions are not followed. This equipment contains moving parts that can start unexpectedly. Injury or death could occur if instructions are not followed. All work should be performed by a qualified technician. Always disconnect and lock out power before servicing. **DO NOT** bypass any interlock or safety switches under any circumstances.

Symptom: Not Enough Heat

POSSIBLE CAUSE	PROBLEM	REMEDIES
Mixing damper operator not operating properly	Outside air dampers open at low ambient temperatures.	Adjust mixed air to warmer setting. Check dampers for proper operation and adjust if necessary. Replace damper operator.
Low gas pressure.	Burner is slow to light. Small flame.	Adjust or replace regulator.
Furnace short cycles on limit switches.	Continual on/off operation of all burners.	Tighten or replace blower belt. Check I.D. fan and switch. Clean or replace filters.

Symptom: No Heat

POSSIBLE CAUSE	PROBLEM	REMEDIES
Blown control module fuse.	Thermostat calling, ventor motor running.	Check for cause of blown fuse, then replace fuse or S825 Module.
Ventor motor air proving switch not operating.	Ventor motor runs, but ignition control board is not powered.	Repair or replace air proving switch.
No gas supply to manifold.	Electrode sparks, gas solenoid opens, but no flame.	Check main gas supply.

Symptom: Flame Roll Out - Flame in Manifold Compartment

POSSIBLE CAUSE	PROBLEM	REMEDIES
Blocked flue / chimney.	Flame roll out switch tripping.	Ensure vent / chimney is clear of obstructions.
Lack of combustion air.	Flame roll out switch tripping.	Increase combustion air.
Leaking gas solenoid valve.	Gas smell in manifold compartment. Flame does not go out immediately when power to burner turned off.	Replace gas valve.
High gas pressure.	Flame billows out from inlet tube	Reset or replace regulator.
Blocked or damaged intake screen.	Discoloration of metal inside burner vestibule.	Repair or clean screen.

