

**EngA**®

**ENGINEERED AIR**®

**INSTALLATION, OPERATION  
AND MAINTENANCE MANUAL**

**FOR**

**Power Venters (DJX and SHX)**

**INDIRECT GAS FIRED CONDENSING APPLICANCES**

**INDOOR MODELS ONLY**

RECOGNIZED  
COMPONENT



Intertek

RECOGNIZED  
COMPONENT



Intertek

UNIT MODEL NO. \_\_\_\_\_  
UNIT SERIAL NO. \_\_\_\_\_  
SERVICED BY: \_\_\_\_\_  
TEL. NO: \_\_\_\_\_

**CANADIAN  
HEAD OFFICE  
AND FACTORY**

1401 HASTINGS CRES. SE  
CALGARY, ALBERTA  
T2G 4C8  
Ph: (403) 287-4774  
Fx: 888-364-2727

**USA  
HEAD OFFICE  
AND FACTORY**

32050 W. 83<sup>rd</sup> STREET  
DESOTO, KANSAS  
66018  
Ph: (913) 583-3181  
Fx: (913) 583-1406

**CANADIAN  
EASTERN FACTORY**

1175 TWINNEY DRIVE  
NEWMARKET, ONTARIO  
L3Y 5V7  
Ph: (905) 898-1114  
Fx: (905) 898-7244

**SALES OFFICES ACROSS CANADA AND USA**

Retain instructions with unit and maintain in a legible condition.  
Please give model number and serial number when contacting  
factory for information and/or parts.

[www.engineeredair.com](http://www.engineeredair.com)

**TABLE OF CONTENTS**

You Have Responsibilities Too .....	3
Introduction.....	3
Safety Precautions.....	3
Warranty .....	4
Parts.....	5
Description .....	5
Installation Restrictions.....	5
Codes .....	6
Specific Code Requirements.....	7
Installation.....	8
Vent Termination .....	8
Power Venter Mounting.....	8
Vent Pipe Installation .....	9
Pressure Transducer Installation.....	9
Basic Carel Electrical Connections.....	11
Vent Fan Control .....	12
Combustion Air.....	12
Prepurge And Postpurge .....	12
Start Up Test.....	12
Masks.....	13
Main Display .....	13
Info .....	13
Setpoints.....	14
Service .....	15
Settings.....	16
Maintenance .....	17
Trouble Shooting.....	18

**Warning:**

These instructions are intended as an aid to qualified, licensed installers and service personnel for proper installation, adjustment and operation of this unit. Read and understand these instructions thoroughly before attempting installation or operation. Failure to follow these instructions may result in improper installation, adjustment, service or maintenance possibly resulting in fire, electrical shock, carbon monoxide poisoning, explosion, personal injury or property damage.

## YOU HAVE RESPONSIBILITIES TOO

This installation, operation and maintenance manual cannot cover every possibility, situation or eventuality. Regular service, cleaning and maintaining the equipment is necessary. If you are not capable of performing these tasks, hire a qualified service specialist. **Failure to perform these duties can cause property damage and/or harm to the building occupants and will void the manufacturers' warranty.**

## INTRODUCTION

Engineered Air units are high quality products designed and manufactured to provide many years of trouble-free operation. We recommend that this manual be read thoroughly to ensure proper installation, efficient operation and proper maintenance of this equipment. The submittal record is considered to be part of the Installation, Operation and Maintenance Manual. Please report any omissions to the national service manager.

## SAFETY PRECAUTIONS

Read, understand and follow the complete manual before beginning the installation, including all safety precautions and warnings.

**Warning:**

**Improper installation, adjustment, alteration, service or maintenance can cause property damage, injury or death. Read the installation, operating and maintenance instructions thoroughly before installing or servicing this equipment.**

**Warning:**

**This unit is connected to high voltages. Electrical shock or death could occur if instructions are not followed. This equipment contains moving parts that can start unexpectedly. Injury or death could occur if instructions are not followed. All work should be performed by a qualified technician. Always disconnect and lock out power before servicing. DO NOT bypass any interlock or safety switches under any circumstances.**

## WARRANTY

**LIMITED WARRANTY** ENGINEERED AIR will furnish without charge, F.O.B. factory, freight collect, replacement parts for, or repairs to products covered herein which prove defective in material or workmanship under normal and proper use for a period of twelve (12) months from the initial start-up or eighteen (18) months from the date of shipment, whichever expires sooner, provided the customer gives ENGINEERED AIR written notice of such defects within such time periods and provided that inspection by ENGINEERED AIR establishes the validity of the claim and all pertinent invoices have been paid in full. The repairs or replacements will be made only when the complete product(s) or part(s) claimed to be defective are returned to ENGINEERED AIR or a depot designated by ENGINEERED AIR, transportation charges prepaid. Repairs or replacements as provided for by this paragraph shall constitute fulfillment of all ENGINEERED AIR's obligations with respect to this warranty. The refrigerant charge is not included in any part of this warranty. This warranty does not apply to any products or parts thereof that have been subject to accident, misuse or unauthorized alterations, or where ENGINEERED AIR's installation and service requirements have not been met.

The foregoing warranty is in lieu of all other warranties, express or implied. ENGINEERED AIR specifically disclaims any implied warranty of merchantability and/or fitness for purpose. Under no circumstances shall ENGINEERED AIR be liable to, nor be required to indemnify, Buyer or any third parties for any claims, losses, labour, expenses or damages (including special, indirect, incidental, or consequential damages) of any kind, resulting from the performance (or lack thereof) of this Agreement or the use of, or inability to use the goods sold hereunder, including, but not limited to, damages for delay, temporary heating/cooling costs, loss of goodwill, loss of profits or loss of use. Furthermore, the parties agree that the Buyer's sole remedy under this Agreement shall be limited to the limited warranty set forth in the preceding paragraph relating to the repair or replacement of any defective goods. Under no circumstances shall any claim or award against ENGINEERED AIR exceed the original contract price whether awarded through arbitration, litigation or otherwise.

ENGINEERED AIR Warranty is void if:

1. The unit is not installed in accordance with this manual.
2. The start-up and operation of the unit is not performed in accordance with this manual.
3. The unit is operated in an atmosphere containing corrosive substances.
4. The unit is allowed to operate during building construction.
5. The unit is allowed to operate in atmospheres where chlorine or chlorine compounds are present or which contain any contaminant (silicone, aluminum oxide etc.) that adheres to the spark ignition flame sensing probe.

## PARTS

Contact the nearest Engineered Air sales office or factory. Be sure to include Model Number, Serial Number, date of installation and nature of failure along with the description of the parts required. Some parts may not be stocked items that must be manufactured or ordered.

## DESCRIPTION

Power Venters are designed to vent Natural and LP Gas heaters or assist vertical discharge installations with where the length of horizontal vent is greater than the vertical.

The Carel controller uses Engineered Air software to continually monitor the vent pressure at a Tee located at the appliance flue and maintain a slight negative pressure. It features a safety system that will disable heating in the event of vent over or under pressure. The power venter control system is enabled and proven whenever the appliance combustion blower is enabled.

All Power Venter selection and sizing must be performed by Engineered Air.

## INSTALLATION RESTRICTIONS

1. The Power Venter may only be installed on Natural Gas or LP Gas heaters.
2. The Power Venter as described in this Installation Operation and Maintenance Manual is only suitable for Engineered Air appliances.
3. The Power Venter must be mounted so that the shaft of the motor remains horizontal to prevent motor bearing wear.
4. Do not mount the Venter Proving Transducer on a heat source that exceeds 140°F (60°C). Examples of improper mounting surfaces include vent pipe, venter, top of heater or humidifier casing or any place where radiant or convective heat would exceed 140°F (60°C).
5. Ambient temperature surrounding Power Venter must not exceed 104°F (40°C). The minimum ambient temperature is 40°F (4°C).

**Caution:**

**All wiring, piping and fuel line installation must be completed by qualified persons in accordance with all federal, state, provincial and/or local codes.**

Note: Installation shall be in accordance with this manual and all other associated component and control Installation, Operation and Maintenance Manuals.

## CODES

### In Canada:

1. The installation of this unit shall be in accordance with the latest edition of the Canadian Electrical Code, Part 1 – C.S.A. Standard C22.1, Provincial and Local Codes, and in accordance with the local authorities having jurisdiction.
2. This unit shall be electrically grounded in accordance with the latest edition of the Canadian Electrical Code, Part 1 – C.S.A. Standard C22.1, Provincial and Local Codes, and in accordance with the local authorities having jurisdiction.
3. The installation of this unit shall be in accordance with the latest edition of the Canadian Natural Gas and Propane Installation Code, C.S.A. Standard B149.1, Provincial and Local Codes, and in accordance with the local authorities having jurisdiction.
4. The installation of this unit shall be in accordance with the latest edition of the National Plumbing Code of Canada, Provincial and Local Codes, and in accordance with the local authorities having jurisdiction.
5. The installation of this unit shall be in accordance with all other National, Provincial and Local Codes, and in accordance with the local authorities having jurisdiction.

### In USA:

1. The installation of this unit shall be in accordance with the latest edition of the National Electrical Code (ANSI/NFPA 70), State and Local Codes and in accordance with the local authorities having jurisdiction.
2. This unit shall be electrically grounded in accordance with the latest edition of the National Electrical Code (ANSI/NFPA 70), State and Local Codes and in accordance with the local authorities having jurisdiction.
3. If the unit has not been provided with an electric disconnect switch, one of adequate ampacity shall be installed in accordance with Article 430 of the National Electrical Code (ANSI/NFPA 70).
4. The installation of this unit shall be in accordance with the latest edition of the National Fuel Gas Code ANSI/Z223.1/NFPA 54, State and Local Codes and in accordance with the local authorities having jurisdiction.
5. The installation of this unit shall be in accordance with the latest edition of the National Standard Plumbing Code (NSPC), State and Local Codes and in accordance with the local authorities having jurisdiction.
6. The installation of this unit shall be in accordance with all other National, State and Local Codes, and in accordance with the local authorities having jurisdiction.

## SPECIFIC CODE REQUIREMENTS

Terminate the vent system so that proper minimum clearances are maintained as cited in the latest edition Canadian Natural Gas and Propane Installation Code, C.S.A. Standard B149.1, Provincial and Local Codes or the National Fuel Gas Code ANSI/Z223.1/NFPA 54, State and Local Codes and in accordance with the local authorities having jurisdiction or as follows:

- Not be less than 7 feet (2100 mm) above grade when located adjacent to public walk ways.
- At least 3 feet (900 mm) above any forced air inlet located within 10 feet (3000 mm).
- At least 4 feet (1200 mm) below, 4 feet (1200 mm) horizontally from or 1 foot (300 mm) above any window or gravity air inlet into any building.
- Do not mount above a door.
- At least 1 foot (300 mm) above grade.
- So that the flue gases are not directed so as to jeopardize people, overheat combustible structures or enter buildings, and
- Not less than 2 feet (600 mm) from an adjacent building.
- Locate the vent termination no closer than 3 feet (900 mm) from an inside corner of an L-shaped structure.

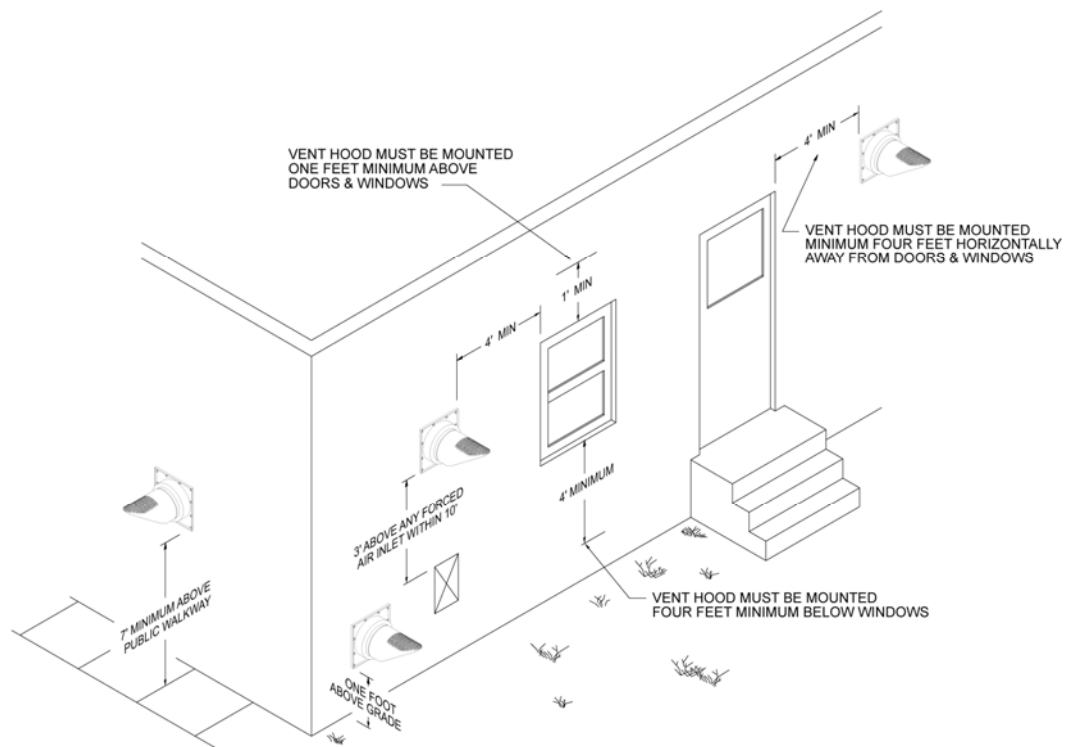

## INSTALLATION

**Warning:**

The Power Venter must be installed by a qualified installer in accordance with these instructions. Improper installation can create a hazardous condition such as an explosion, fire, electrical shock or carbon monoxide poisoning resulting in property damage, personal injury or death.

**Warning:**

Failure to install, maintain and/or operate the Power Venter in accordance with manufacturer's instructions may result in conditions which can produce bodily injury and property damage.

## VENT TERMINATION

An Engineered Air horizontal vent outlet must be installed at the termination point of the vent system. Do not install the Engineered Air Vent Termination vertically, use an approved BH rain cap.

If possible, locate the Vent Hood on a wall that does not face the direction of prevailing winds. This will diminish the possibility of operational interruption during periods of extreme winds.

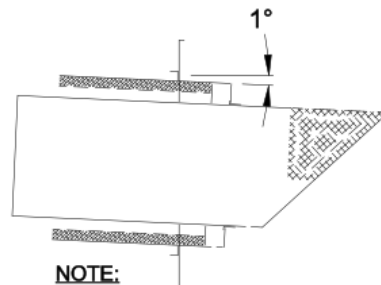
**NOTE:**

FLUE ASSEMBLY TILTED APPROXIMATELY 1°  
AGAINST WALL MTG PLATE

## POWER VENTER MOUNTING

Typically mounted on the heating appliance, the Venter may be firmly mounted in any position as long as the shaft of the motor remains horizontal. The Venter housing is single wall and 12 inches (300 mm) must be maintained from all combustible materials. The Venter shall be firmly mounted



as close as possible to the point of termination. Ensure all available drain connections are trapped and connected.

## VENT PIPE INSTALLATION

Venting must be Type BH rated for Category IV appliances. The Power Venter inlet and outlet, and the Engineered Air Vent Termination are designed to only accept single wall vent pipe. The installer must supply minimum 22ga. 316L stainless steel adapters to connect. The size of the vent pipe before or after the Power Venter shall be the size as selected by Engineered Air. Support the vent pipe as recommended by the vent pipe manufacturer.

**Caution:**  **Elbows placed directly after discharge on Power Venter may cause erratic operation. If elbows are necessary on discharge, allow for a straight section of pipe 3 times the vent diameter being used before installing an elbow.**

## PRESSURE TRANSDUCER INSTALLATION

Mount the Venter Proving transducer onto a stable, non-vibrating location, in the vertical position. Do not mount the onto a heat source that could exceed 140°F (60°C). Examples of improper mounting surfaces include vent pipe, venter, top of heater or humidifier casing or any place where radiant or convective heat would exceed 140°F (60°C). The transducer must be mounted above the vent connection point to avoid moisture being trapped within the tubing.

### Configuration

The transmitter is configured with switches located on the circuit board. These switches are used to select the output signal type and the input pressure range. The unit is factory configured to operate in the **4-20 mA** output mode. Do not use the voltage output.

The pressure range switches must be set to **LOW** ( $\pm 1''$ wc) and **+/-** both **ON**.  
**The default setpoint is -0.05''w.c.**

**POWER VENTER (DJX SHX)**

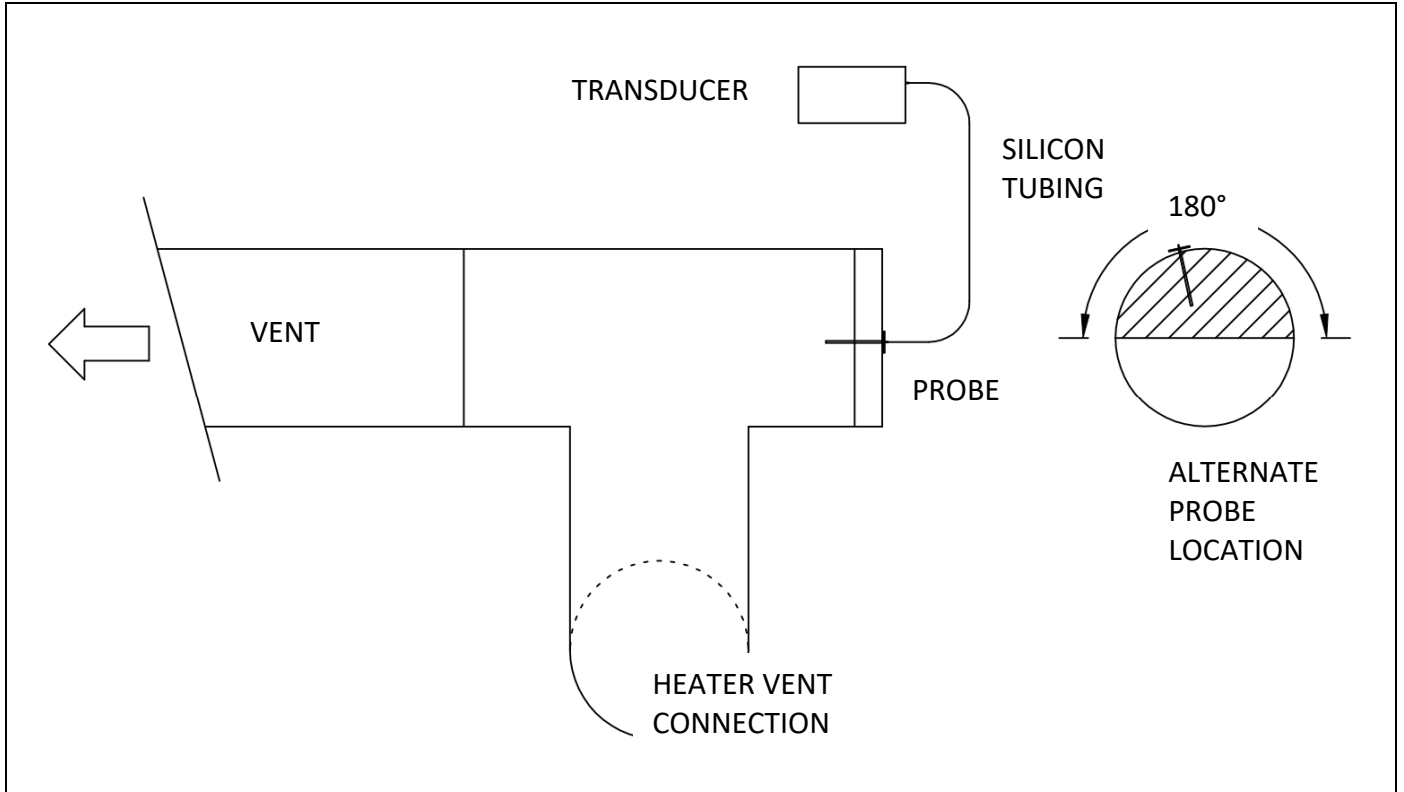

**BASIC CAREL ELECTRICAL CONNECTIONS**

The drawing below is generic, for reference only. Always refer to the electrical drawing(s) included with the equipment.

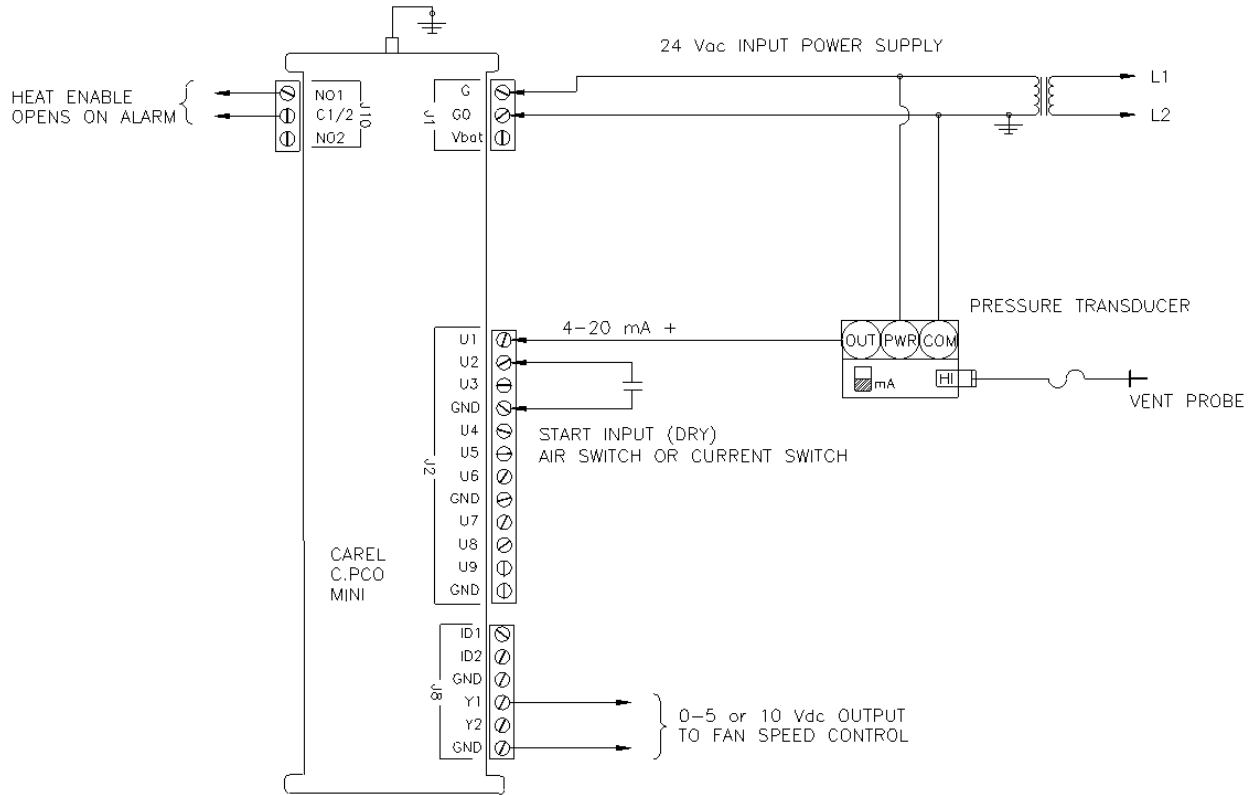

## VENT FAN CONTROL

The power vent fan speed output is controlled from a 0-5V or 0-10 Vdc output on the controller. Fan motor speed control is factory preset, and varies depending on the application (VFD, inverter, or EC motor).

## COMBUSTION AIR

Adequate combustion air is vital for proper combustion, safe venting and for proper Power Venter performance. Many installers assume adequate combustion air is present, especially in older buildings. In some cases this is a false assumption, because many older buildings have been weatherized. Size the combustion air opening(s) as outlined in local or national codes. When installing a Power Venter it is not necessary to supply any more combustion air than normally required when using conventional venting. Common symptoms of inadequate combustion air include: Venter short cycling, odor present at end of burner cycle, outside air enters the structure through the Power Venter during off cycle.

## PREPURGE AND POSTPURGE

Purge mode and time is intrinsic to the primary heating controller. The power vent control will remain active and operational as long as the combustion blower is on.

## START UP TEST

- 1 If using a separate supply, enable power to the Power Vent control circuit (and VFD / inverter power if applicable).
- 2 Disconnect the sensing tube from the vent.
- 3 The Main page should display: Vent Request: **NO**, Blower: **0%** and Pressure: **0.00**.
- 4 Enable the heating appliance and its combustion air fan.
- 5 The Main page should now display: Vent Request: **YES**
  - a. The Vent Blower will speed up to 100%.
  - b. Confirm fan rotation is correct.
- 6 Reconnect the sensing tube to the vent.
- 7 The Vent Blower should reduce speed and begin to control to setpoint (-0.05" w.c.).
- 8 Continue the startup procedure of the heating appliance.

## MASKS

### MAIN DISPLAY



The main display mask shows the present date and time, the actual measured pressure, the request to operate from the heating device combustion fan, and the power vent fan motor current operating speed.

### INFO

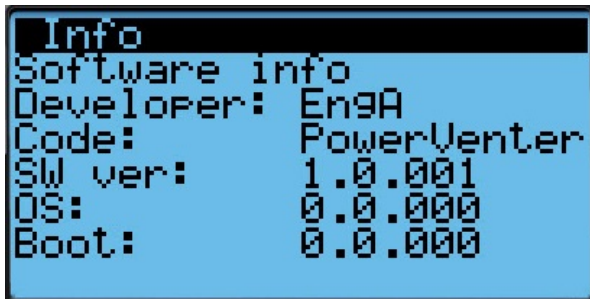

Describes the software version details.



Additional board details.



Displays the operational time of the controller and program. This is not the total powered time of the control.

```
Info
Blackout info
Current time:
22/03/16      09:35:26
PowerOff time:
00/00/##     00:00:00
Length last time off:
18Days 10Hrs 2Min
```

Indication if there is a loss of main power.

## SETPOINTS

```
Setpoints
SYSTEM SETTINGS
Setpoint:      -0.05
Heat Delay:    2 sec
```

Controller vent pressure setpoint. The default setting is -0.05. This setpoint should not need to be altered.

```
Setpoints
HIGH PRESSURE SETTINGS
Setpoint:      0.05
Alarm Delay:   10 sec
```

The high (over) pressure setpoint and alarm delay. Setting is set to just slightly positive pressure with a 10 second delay before locking out the system.

```
Setpoints
LOW PRESSURE SETTINGS
Setpoint:      -0.20
Alarm Delay:   10 sec
```

The low pressure setting and alarm delay. If the control operates below this setpoint for more than 10 seconds the control will lock out the system and go into alarm condition.

**POWER VENTER (DJX SHX)**

```

SetPoints
PID LOOP SETTINGS
Kp:          75.0
Ti:          2
Td:          1

```

This mask lists the proportional, integral and derivative control loop parameters. Kp = Proportional Band (default: 75)  
 Ti = Integral (default: 2)  
 Td = Derivative (default: 1)

These values should only be changed by service personnel extremely familiar with the operation of the system and controller.

```

SImport/Export
Import/Export:
IMPORT
Memory type:
INTERNAL FLASH MEMORY
File name:   EXPORT_00
Confirm:    NO

```

Program import and export mask used to load and unload the operating program.

**SERVICE**

```

Service
Inverter:    NO
Startup Delay: 10 sec
U1 Sensor:   12.0 mA

```

Inverter output is 0-10 Vdc while the ECM option is 0-5 Vdc.

Start up delay allows the vent fan to ramp up and stabilize before allowing the heat to operate.

U1 Sensor shows the actual mA signal from the pressure sensor.

```

Alarms History
NO LOGS

```

The alarm mask shows all previous alarms along with the type of alarm and the date and time of the event.

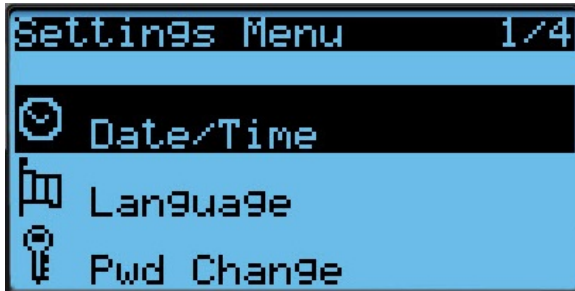
**SETTINGS**

Revolving selection screen for settings.  
Includes:

- Date and Time
- Language
- Password Change
- Initialization

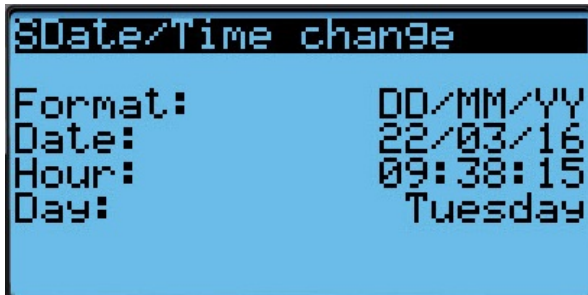

Present date and time.

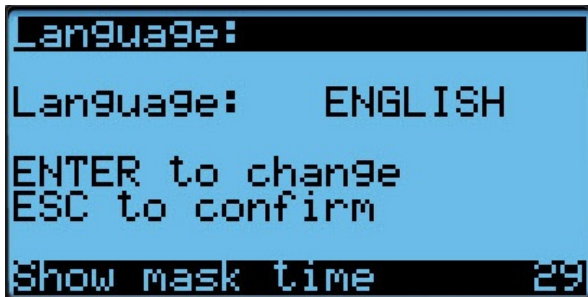

Default language is English.

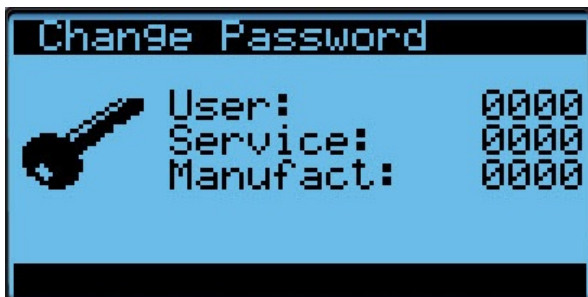

The default controller and setup from factory will not have a password. The end user may select a password at their own discretion.



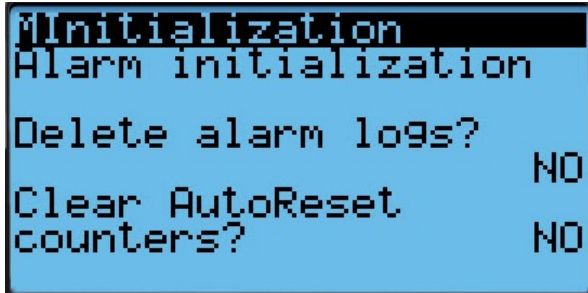

Mask to clear alarm and reset counter log.

## MAINTENANCE

1. For fractional HP motors, oil every six months with 2 drops of S.A.E #20. The oil ports are located at both ends of the motor. For larger HP motors refer to the motor manufacturer for lubrication recommendations. Recommended motor lubrication operating less than 12 hours per day is every 5 years; motors operating greater than 12 hours per day should be lubricated every 2 years. On motors having grease drain plugs, remove the plugs and operate the motor for 15 minutes before replacing plugs. **DO NOT OVER GREASE.**
2. Semi-annually inspect the Vent Termination and vent pipe for blockage, corrosion and leaks.
3. A vent system inspection must be performed annually by qualified service personnel. The inspection should include an operational check, safety interlock test, combustion air test and a visual inspection of the complete vent system, including drains, for corrosion, blockage or leaks. Any corrosion, blockage or leaks detected must be repaired or replaced immediately.

## TROUBLE SHOOTING

<b>Alarm</b>	<b>Description</b>	<b>Possible Causes</b>
High Pressure Alarm	The system pressure measured by the sensor is higher than the High Pressure setpoint and has exceeded the alarm delay time.	<ul style="list-style-type: none"> <li>• Fan not operational.</li> <li>• Too large of load for the fan capacity.</li> <li>• Vent blockage.</li> <li>• Sensing tube blocked or restricted.</li> <li>• Induced voltage into the pressure sensor signal wire.</li> </ul>
Low Pressure Alarm	The system pressure measured by the sensor is lower than the Low Pressure setpoint and has exceeded the alarm delay time.	<ul style="list-style-type: none"> <li>• High natural draft.</li> <li>• Induced voltage into the pressure sensor signal wire.</li> <li>• Sensing tube blocked or restricted.</li> <li>• Pressure transmitter failure.</li> <li>• Vent fan or motor issue.</li> </ul>

<b>Issue Description</b>	<b>Actions</b>
Fan will not run.	<ul style="list-style-type: none"> <li>• Check supply voltage.</li> <li>• Check disconnect.</li> <li>• Verify wiring.</li> <li>• Verity control settings.</li> </ul>
Pressure transducer not working.	<ul style="list-style-type: none"> <li>• Check supply voltage at transducer terminals.</li> <li>• Verify wiring.</li> <li>• Check sensing tube and/or probe.</li> <li>• Verify transducer mounting orientation.</li> </ul>
System has wide pressure swings (hunting).	<ul style="list-style-type: none"> <li>• Check pressure probe location.</li> <li>• Check PID loop settings.</li> </ul>