

**EngA**®

**ENGINEERED AIR**®

**INSTALLATION, OPERATION  
AND MAINTENANCE MANUAL  
FOR  
FW(A,B,D,E) & UP(A,E,W) SERIES**

**PACKAGED AIR CONDITIONING UNITS  
INDOOR AND OUTDOOR MODELS**



**Intertek**



**Intertek**

UNIT MODEL NO. \_\_\_\_\_  
UNIT SERIAL NO. \_\_\_\_\_  
SERVICED BY: \_\_\_\_\_  
TEL. NO: \_\_\_\_\_

**CANADIAN  
HEAD OFFICE  
AND FACTORY**

1401 HASTINGS CRES. SE  
CALGARY, ALBERTA  
T2G 4C8  
Ph: (403) 287-2590  
Fx: 888-364-2727

**USA  
HEAD OFFICE  
AND FACTORY**

32050 W. 83<sup>rd</sup> STREET  
DESOTO, KANSAS  
66018  
Ph: (913) 583-3181  
Fx: (913) 583-1406

**CANADIAN  
EASTERN FACTORY**

1175 TWINNEY DRIVE  
NEWMARKET, ONTARIO  
L3Y 5V7  
Ph: (905) 898-1114  
Fx: (905) 898-7244

**SALES OFFICES ACROSS CANADA AND USA**

Retain instructions with unit and maintain in a legible condition.  
Please give model number and serial number when contacting  
factory for information and/or parts.

[www.engineeredair.com](http://www.engineeredair.com)

February 12 R2

**TABLE OF CONTENTS**

YOU HAVE RESPONSIBILITIES TOO.....	3
INTRODUCTION .....	3
SAFETY PRECAUTIONS.....	3
WARRANTY .....	4
PARTS.....	4
RECEIVING.....	5
TEMPORARY STORAGE .....	5
INSTALLATION .....	5
MINIMUM CLEARANCE TO COMBUSTIBLES AND FOR SERVICE IN INCHES (mm).....	6
CLEARANCE FOR CONDENSER AIR FLOW .....	6
LIFTING.....	7
MOUNTING .....	7
SHIPPING MATERIALS .....	8
ASSEMBLY .....	8
PIPING, ELECTRICAL OR CONTROL SERVICE CONNECTIONS.....	9
ELECTRICAL INSTALLATION .....	9
Recommended 24V Field Wiring Size:.....	10
DUCT MOUNTED TE-6000-EA3 TEMPERATURE SENSOR.....	11
COIL CONNECTIONS.....	11
DRAIN TRAPS.....	11
FLUSHING AND DEGREASING OF WATER AND GLYCOL COILS.....	12
HEAT TRANSFER FLUIDS .....	12
BEFORE START-UP .....	13
START-UP CHECK LIST.....	13
OPERATION .....	16
REFRIGERATION CONTROLS .....	16
REFRIGERANT HANDLING .....	19
COMPRESSOR OIL .....	19
SHUTDOWN PROCEDURE.....	20
CHARGING INSTRUCTIONS .....	20
ENGA INTERCOOLER.....	21
CONTROL SETTINGS .....	21
MAINTENANCE.....	22
ELECTRICAL .....	22
BELT ADJUSTMENT.....	22
SET SCREWS.....	23
BEARING SETSCREW TORQUES.....	23
LUBRICATION OF FAN BEARINGS.....	24
LUBRICATION OF DODGE FAN BEARINGS.....	24
MOTOR LUBRICATION .....	26
FILTERS.....	26
CONTROLS.....	27
CONTROL ENCLOSURE VENTILATION .....	27
OUTDOOR AIR INTAKES, MIXING SECTIONS AND DAMPERS.....	27
COILS.....	28
HEATING.....	28
REFRIGERATION .....	28

© Airtex Manufacturing Partnership. All rights reserved.

## YOU HAVE RESPONSIBILITIES TOO

This installation, operation and maintenance manual can not cover every possibility, situation or eventuality. Regular service, cleaning and maintaining the equipment is necessary. If you are not capable of performing these tasks, hire a qualified service specialist. **Failure to perform these duties can cause property damage and/or harm to the building occupants and will void the manufacturers' warranty.**

## INTRODUCTION

Engineered Air units are high quality products designed and manufactured to provide many years of trouble-free operation. We recommend that this manual be read thoroughly to ensure proper installation, efficient operation and proper maintenance of this equipment. The submittal record is considered to be part of the Installation, Operation and Maintenance Manual. Please report any omissions to the national service manager.

## SAFETY PRECAUTIONS

Read, understand and follow the complete manual before beginning the installation, including all safety precautions and warnings.

**Warning:**  **Improper installation, adjustment, alteration, service or maintenance can cause property damage, injury or death. Read the installation, operating and maintenance instructions thoroughly before installing or servicing this equipment.**

**Warning:**  **This unit is connected to high voltages. Electrical shock or death could occur if instructions are not followed. This equipment contains moving parts that can start unexpectedly. Injury or death could occur if instructions are not followed. All work should be performed by a qualified technician. Always disconnect and lock out power before servicing. DO NOT bypass any interlock or safety switches under any circumstances.**



## WARRANTY

**LIMITED WARRANTY** ENGINEERED AIR will furnish without charge, F.O.B. factory, freight collect, replacement parts for, or repairs to products covered herein which prove defective in material or workmanship under normal and proper use for a period of twelve (12) months from the initial start-up or eighteen (18) months from the date of shipment, whichever expires sooner, provided the customer gives ENGINEERED AIR written notice of such defects within such time periods and provided that inspection by ENGINEERED AIR establishes the validity of the claim and all pertinent invoices have been paid in full. The repairs or replacements will be made only when the complete product(s) or part(s) claimed to be defective are returned to ENGINEERED AIR or a depot designated by ENGINEERED AIR, transportation charges prepaid. Repairs or replacements as provided for by this paragraph shall constitute fulfillment of all ENGINEERED AIR's obligations with respect to this warranty. The refrigerant charge is not included in any part of this warranty. This warranty does not apply to any products or parts thereof that have been subject to accident, misuse or unauthorized alterations, or where ENGINEERED AIR's installation and service requirements have not been met.

The foregoing warranty is in lieu of all other warranties, express or implied. ENGINEERED AIR specifically disclaims any implied warranty of merchantability and/or fitness for purpose. Under no circumstances shall ENGINEERED AIR be liable to, nor be required to indemnify, Buyer or any third parties for any claims, losses, labour, expenses or damages (including special, indirect, incidental, or consequential damages) of any kind, resulting from the performance (or lack thereof) of this Agreement or the use of, or inability to use the goods sold hereunder, including, but not limited to, damages for delay, temporary heating/cooling costs, loss of goodwill, loss of profits or loss of use. Furthermore, the parties agree that the Buyer's sole remedy under this Agreement shall be limited to the limited warranty set forth in the preceding paragraph relating to the repair or replacement of any defective goods. Under no circumstances shall any claim or award against ENGINEERED AIR exceed the original contract price whether awarded through arbitration, litigation or otherwise.

ENGINEERED AIR Warranty is void if:

1. The unit is not installed in accordance with this manual.
2. The start-up and operation of the unit is not performed in accordance with this manual.
3. The unit is operated in an atmosphere containing corrosive substances.
4. The unit is allowed to operate during building construction.
5. The unit is allowed to operate in atmospheres where chlorine or chlorine compounds are present or which contain any contaminant (silicone, aluminum oxide etc.) that adheres to the spark ignition flame sensing probe.

## PARTS

**Warning:**

**Any replacement part must be of equivalent listing or certification and be functionally equivalent. The replacement part must meet the original's specification in terms of functionality including certifications, timing, input and output range, accuracy and operation.**



**Failure to replace parts or components with equivalent parts can cause property damage, injury or death.**

1. Motors:  
Motor manufacturers have service centers that will repair or replace motors as required.

2. Parts Other Than Motors:  
Contact the nearest Engineered Air sales office or factory. Be sure to include Model Number, Serial Number, date of installation and nature of failure along with the description of the parts required. Some parts may not be stocked items that must be made or ordered.

## RECEIVING

Refer to the back of the packing slip for receiving unit instructions.

On receipt of the unit, check for damage. Inspect protective covers for punctures or other signs that there may be internal damage. Remove protective covers and check for internal damage. Replace covers if the unit is not being assembled or installed at this time. Open access doors and check for internal damage. Close access doors when the inspection is complete.

All units are pre-tested at the factory immediately prior to shipping and are ensured to be in good operating condition at that time. If damage is found follow the instructions on the packing slip.

On receipt of the unit, check electrical characteristics (see rating plate) to make sure the unit voltage is compatible with that available for the unit. All parts for field installation are listed on the shipping order form.

## TEMPORARY STORAGE

If a unit is to be stored prior to installation the following precautions are required:

- Store in a well drained area that will not accumulate surface water.
- Store in an area where the unit will not get damaged.
- The entire perimeter and any full height cross members of the unit must be supported by a level surface and the supporting surface must be adequate for supporting the entire weight of the unit.
- All protective coverings that were provided for shipping must be in place.
- Protect indoor units from rain and snow.

## INSTALLATION

**Warning:**

**Only equipment bearing a CSA C22.2 No. 213 or UL 1604 rating plate (label) with an accompanying CSA Certification mark is suitable for installation in a hazardous location. The hazardous location must conform with the Class, Division, Group and temperature code (if shown) displayed on the rating plate (label).**

**If not marked as noted above, the unit is not rated for hazardous locations and should not be installed in areas requiring any hazardous location rating.**

**MINIMUM CLEARANCE TO COMBUSTIBLES AND FOR SERVICE IN INCHES (mm)**

MODEL	COMBUSTIBLE CLEARANCE					SERVICE CLEARANCE	
	TOP	FRONT	BACK	SIDE	BOTTOM	SERVICE SIDE	CONTROL PANEL †
<b>ELECTRIC HEAT</b>	1" (25)	1" (25)	6" (152)	1" (25)	0	UNIT WIDTH + 10" (254)	42" (1067)
<b>FLUID COILS &amp; RECOVERY DEVICES</b>	1" (25)	1" (25)	1" (25)	1" (25)	0	UNIT WIDTH	42" (1067)
<b>OTHER UNITS</b>	1" (25)	1" (25)	1" (25)	1" (25)	0	24" (610)	42" (1067)

† - As required by the Canadian Electrical Code or the National Electrical Code. For Safety and Service, the minimum clearances must be observed.

**CLEARANCE FOR CONDENSER AIR FLOW**

Proper air flow is essential for the operation of this equipment. Maintain at least 60" (1500 mm) clearance between the condenser coil and any obstruction. Maintain at least 96" (2400mm) between adjacent condensing sections. Do not place condenser sections in a well. Wells create a situation where air re-circulates from the condenser fan back to the condenser coil. Enclosures must be designed for proper air flow and to prevent blockage or re-circulated air.

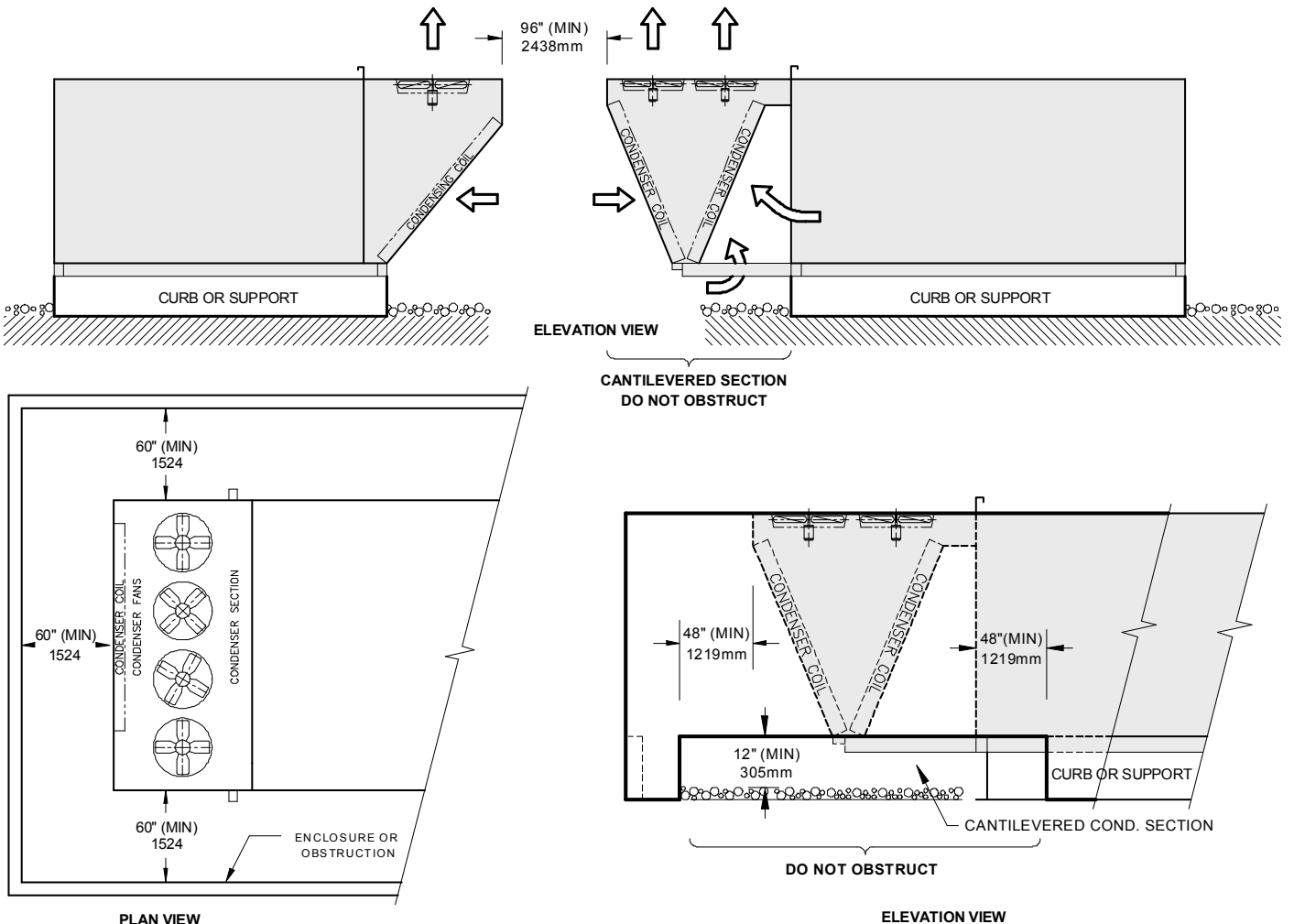

## LIFTING

Engineered Air units are constructed on a structural steel base frame. The unit base frame is equipped with lifting lugs specifically located to facilitate proper lifting of the unit. Spreader bars must be used to keep rigging away from the unit cabinetry. All lifting lugs must be used. If using a lift truck, ONLY lift using the perimeter structural frame. **DO NOT** allow forks to lift on cabinet or unit floor.

Note: There may be bottom mounted components, such as drain piping, that can be easily damaged.

### **Warning:**



**Injury or death can result from improper rigging and lifting. Rigging and lifting of equipment must be performed by qualified personnel with proper equipment using appropriate and approved safety precautions.**

## MOUNTING

Units must be mounted level. Failure to do so can cause water to be trapped in drain pans or operational problems that can void warranty. Failure to do so can result in injury or death, damage the equipment and/or building and can be a cause of poor indoor air quality.

Equipment must be installed so that sufficient working clearance and component access is provided. Some units are designed for cantilevered installation. Consult the Submittal Record for specific unit mounting.

Consult the Submittal Record for specific unit mounting. Engineered Air units are constructed for three types of mounting:

1. Base mounting – Consult the Submittal Record for type of mounting. Unless the unit is specifically designed for point or other mounting, the base of the unit must be supported continuously by a mounting support system that is directly below the unit structural base frame and runs the entire length and width of the unit. Refer to the Submittal Record for mounting information. Units 100” (2500mm) wide and under can be supported on each side continuously along the length of the unit. As a minimum, sleepers that are installed perpendicular to the length of the unit must be continuous across the width of the unit and shall be installed at the end lifting point base rails and the lesser of 80” (2000mm) on center or at all lifting points.
2. Suspended mounting – Where units have been designed for suspended mounting, factory provided connections for hanger rods will be provided. All hanger rod supports must be used. Suspended units must be protected from damage. When installed in aircraft hangers, parking garages or repair garages the installation must comply where applicable with:
  - a) The Canadian Natural Gas and Propane Installation Code, C.S.A. Standard B149.1
  - b) The Standard on Aircraft Hangers, ANSI/NFPA 409
  - c) The Standard on Parking Garages, ANSI/NFPA 88A
  - d) The Standard on Repair Garages, ANSI/NFPA 88B
3. Roof curb mounting – The curbs are constructed of heavy gauge load bearing, galvanized steel, and must be fully insulated after installation. Wood nailer strips are provided for easy attachment of roof flashing. Gasket material is supplied with the unit and must be field mounted on the curb to seal the joint between the curb and the unit frame. The curb must be supported along its entire perimeter and any full height cross members as shown on the shop drawings. Point loading of curbs is not permissible.

The gasket material provided for the curb is closed cell foam. Closed cell foam is dense and does not compress easily. If the unit is split and shipped in sections there will also be gasket material for sealing between sections. The gasket material for splits is open cell foam. It is less dense than the closed cell foam and compresses easily.

**ONLY USE THE CLOSED CELL FOAM GASKET PROVIDED FOR SEALING THE CURB.**

Curbs may be broken down for shipping. Field assembly is required by the installing contractor. Bolt all sections together at split joints using hardware provided. The installing contractor must caulk and seal all joint and corner flashings. All flashings and braces that are provided must be installed. **DO NOT** screw/penetrate joint, corner or adaptor flashings. Refer to assembly instructions sent with roof curb.

## SHIPPING MATERIALS

Remove shipping materials. Shipping materials may include, but are not limited to:

- Protective covers over openings, inlets, condenser coils etc.
- Protective covers over split sections if provided.
- Tie-down bolts, straps and blocks on fan and compressor vibration isolators.
- Tie-down bolts, straps and blocks on tilt equipped heat pipes and enthalpy/desiccant wheels if supplied.
- Indirect fired heat exchangers may be supported with wood for shipping. Remove.

## ASSEMBLY

**Warning:** **Assembly of split units requires bolting together the base frame of adjacent sections. This may require personnel to work under the unit during assembly. Injury or death can result from improper support or improper loading of the curb. Additional temporary support shall be provided by the installer for the safety of personnel.**



If the unit is split and shipped in sections, the sections must be field assembled. All sections are pre-drilled for assembly. The hardware and gaskets are packed in one of the sections. Apply the gasket, align the sections. The base frame must be bolted together first. Access below the unit for bolting of the base frame must be provided. Once the base frame has been tightly fastened, loosely assemble all the bolts and nuts, and then tighten. Caulk all split lines. Install split joint caps. The inlet hood is designed for field installation. On outdoor units connect the hood to the support flange and attach with appropriate fasteners.

### Split unit wiring

All split wiring must be completed by an electrician prior to starting the equipment. A number of different methods are used to reconnect the wiring.

**Power wire:** this wiring is generally not broken or spliced, and will extend from the device back to the contactor or terminal block inside the electrical panel(s). The wire will be tagged to identify which panel it extends to and will be numbered to the corresponding connection.

The location of the equipment split line may result in the wire being disconnected at the device it is feeding. The wire bundle will be tagged and identified. Confirm correct rotation of 3 phase devices after the wiring connections has been completed.



Control wire: this wire is typically broken near the split line, to be reconnected at either a enclosed terminal block, junction box or extended to a nearby control panel. Each wire or wire bundle will be tagged and numbered to indicate the location it is sent to.

Sensor wire shield: The drain wire from the shield must be grounded (at one end only). A ground connection point is available for connection at the point of termination.

All loose wiring must be securely fastened to the equipment casing upon completion.

### PIPING, ELECTRICAL OR CONTROL SERVICE CONNECTIONS

**DO NOT install anything that will interfere with equipment access or the rating plate.**

Engineered Air equipment is constructed with cabinet and floors designed to prevent water from entering the building through the installed unit. When ordered, factory installed pipe chases and/or electrical chases are built into the unit floor. Factory chases are provided with covers that need to be replaced and sealed after piping and electrical connections are made.

**THE FLOOR OF THE UNIT HAS BEEN MADE WATER-RESISTANT. DO NOT CUT OR DRILL HOLES IN THE FLOOR OR USE PENETRATING FASTENERS.**

**All penetrations through the unit walls must be caulked and sealed to prevent air and/or water from entering the unit.**

### ELECTRICAL INSTALLATION

**DO NOT install anything that will interfere with equipment access or the rating plate.**

The unit must be electrically grounded and all wiring must be installed in accordance with the National Electrical Code, ANSI/NFPA 70, and/or the Canadian Electric Code CSA 22-1 and to the approval of the authorities having jurisdiction. **THE FLOOR OF THE UNIT HAS BEEN MADE WATER-RESISTANT. DO NOT CUT OR DRILL HOLES IN THE FLOOR OR USE PENETRATING FASTENERS.** Field wiring diagrams, internal wiring diagrams and operating functions are included in the control cabinet. The power requirements are indicated on the rating plate. Where field wiring of control circuits is required, take care to size the field wiring for a maximum 10% voltage drop. The control circuit ampacity is noted on the field wiring diagram. See the field wiring diagram for requirements for shielded or twisted pair wire for solid state devices.

<b>Caution:</b> 	<b>Temporary Power Generation</b>  <b>The warranty will be void if the voltage being fed from any temporary generator is not within 10% of the nominal rated nameplate voltage and voltage imbalance shall be limited to 2%. A power monitor shall be installed by others to properly monitor power quality and conditions.</b>  <b>All generator sets shall be provided with overcurrent and earth-fault protection. The protective apparatus should be capable of interrupting, without damage, any short-circuit current that may occur.</b>
--	---

**Warning:**

**No unspecified external load shall be added to the control transformer circuit(s) or to the main power circuit(s).**

**Recommended 24V Field Wiring Size:**

Copper conductors only

Circuit Load (Amps) (1)	Maximum Total Length of Run									
	< 50 Ft (~ 15 m)	< 100 Ft (~ 30 m)	< 150 Ft (~ 45 m)	< 200 Ft (~ 60 m)	< 250 Ft (~ 75 m)	< 300 Ft (~ 90 m)	< 350 Ft (~ 105 m)	< 400 Ft (~ 120 m)	< 450 Ft (~ 135 m)	< 500 Ft (~ 150 m)
1	16 AWG	16 AWG	16 AWG	16 AWG	16 AWG	16 AWG	14 AWG	14 AWG	14 AWG	12 AWG
2	16 AWG	16 AWG	16 AWG	14 AWG	12 AWG	12 AWG	12 AWG	10 AWG	10 AWG	10 AWG
3	16 AWG	16 AWG	14 AWG	12 AWG	12 AWG	10 AWG	10 AWG	10 AWG		
4	16 AWG	14 AWG	12 AWG	10 AWG	10 AWG	10 AWG				
5	16 AWG	12 AWG	12 AWG	10 AWG						
6	16 AWG	12 AWG	10 AWG	10 AWG						
7	14 AWG	12 AWG	10 AWG							
8	14 AWG	10 AWG	10 AWG							
9	14 AWG	10 AWG								
10	12 AWG	10 AWG								
11	12 AWG	10 AWG								
12	12 AWG	10 AWG								
13	12 AWG									
14	12 AWG									
15	12 AWG									

**Notes:**

- 1) The field wiring load depends on the actual load on a particular control circuit the field wiring is connected to. Refer to the internal wiring diagram of the unit.
- 2) The table above is based on a maximum 10% voltage drop on a 24V control circuit. Wire size was calculated using the following formula:

$$CM = (25 \times I \times L) / V$$

Where **CM** is circular mils of conductor for a constant load of **I** amps, wire length **L** in feet from the unit to the field device and back, and voltage drop **V**.

When connecting to a three phase power supply, check for the correct rotation of all motors and fans. If the rotation is incorrect, reverse the rotation at the incoming power only. All electrical conduit outlets in the control panel must be sealed to prevent moist building air from migrating to the control panel.

**All penetrations through the unit walls must be caulked and sealed to prevent air and/or water from entering the unit.**

## DUCT MOUNTED TE-6000-EA3 TEMPERATURE SENSOR

Some applications require field installed discharge air sensors.

The sensor strip must be parallel to the air flow. The sensor should be mounted near the center of a straight duct 5 to 10 feet (1500 to 3000mm) downstream of the supply air connection to the Engineered Air unit. Avoid installing near duct transitions or elbows.

Use twisted pair or shielded wiring. The ground shield should be grounded only at the unit control panel end. Protect the opposite end ground and any unused wire with electrical tape.

When installing an Engineered Air TE-6000-EA3 duct mounted temperature sensor, the sensor strip must be parallel to the air flow as shown.

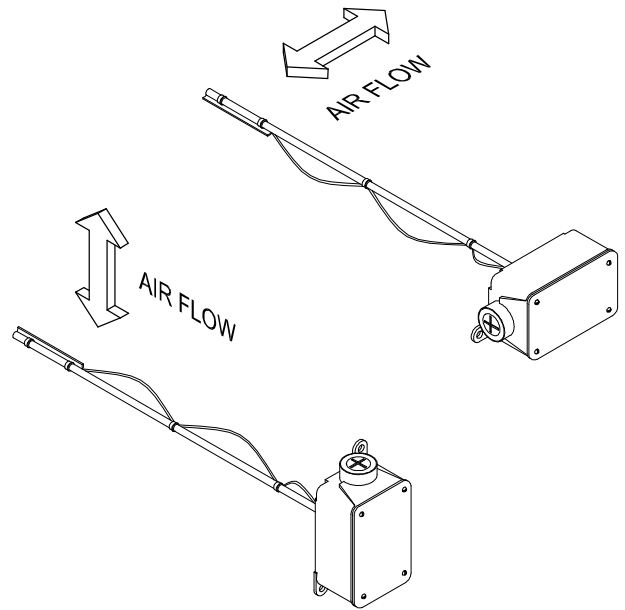

## COIL CONNECTIONS

This equipment may require field connection of water, steam or refrigerant coils. For proper operation airflow must be counterflow to the flow of the fluid. The inlet water connection is normally at the bottom of one header and the outlet water connection at the top of the other header. The steam connection is at the middle of the supply header and the condensate is at the bottom of the other header.

### **Caution:**



**Use a backup wrench on threaded coil connections when installing piping.**

For refrigerant coils, all piping is to be installed by a qualified refrigeration mechanic. All refrigeration specialties shall be installed using good refrigeration installation and design practices.

Recovery, reuse, recycling, reclamation, and safe disposal of refrigerant is the only acceptable practice today. Venting of refrigerant into the atmosphere during installation or servicing is unacceptable. To avoid damage, use an accepted refrigerant recovery system whenever removing refrigerant. When working with refrigerants you must comply with all local government safety and environmental laws.

## DRAIN TRAPS

Each drain connection requires a separate drain trap supplied and installed by the contractor. For a trap to work properly, it must be primed. During freezing periods, primed traps may need to be heat traced or drain and plug the trap when not in use. If a drain connection has a smaller pipe inside, connect to the outer pipe only. Ensure that the trap is of adequate depth to operate against a static that includes the extra pressure drop for dirty filters.

### **Warning:**



**Failure to properly trap each connection can result in drain pan flooding, standing water in unit, building damage, injury or death, cause poor air quality or other problems.**

In some applications (e.g. heat recovery units) there may be additional drain connections inside the curb intended to be connected to the building drainage system. These drains must be connected and properly trapped.

Cooling coil drain pans may have multiple drain connections extending outside the unit casing. Multiple drains may be connected to a common drain providing that each drain is individually trapped and vented to avoid problems from drains in different pressure zones. The drain must be properly sized and sloped.

Size drain trap with the following minimum requirements:

a) Units With Draw Through Drain Pans:

$$H1 = \text{Negative Static}^\dagger \times 1.5 + 3.5" \text{ (89mm)}$$

$$H2 = \text{Negative Static}^\dagger \times 0.75 + 2.5" \text{ (64mm)}$$

b) Units With Blow Through Drain Pans:

$$H2 = \text{Maximum Positive Static}^\dagger \times 1.5$$

$$H1 = H2 + 0.5" \text{ (13mm)}$$

† Static Water Column (WC) in inches or mm including fully loaded filters.

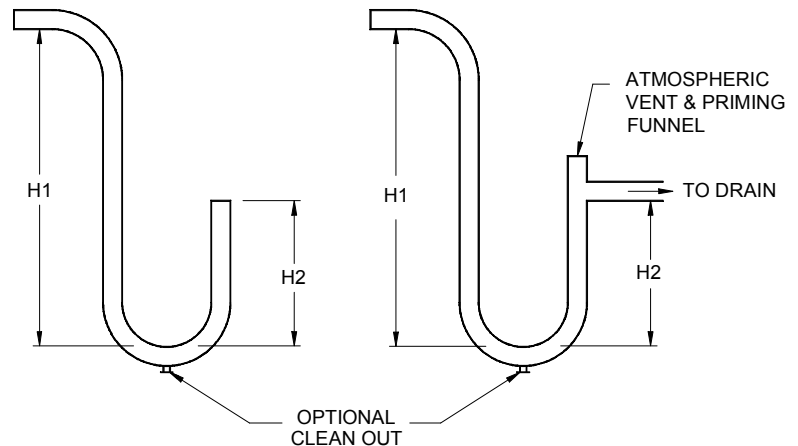

Ensure adequate clearance for properly sized drain traps.

### FLUSHING AND DEGREASING OF WATER AND GLYCOL COILS

Coil tubing may contain material or residue from manufacturing, transportation or storage. To prevent possible damage to other components in the system, the coils must be flushed and degreased. Consult a qualified water treatment specialist.

### HEAT TRANSFER FLUIDS

The coil(s) provided have been selected for use with a specific heat transfer fluid as shown on the Submittal Record. Use of other fluids will result in different performance and can damage the coil(s).



It is imperative to properly select and apply heat transfer fluids used in heating and cooling systems. Untreated, improperly treated or improper use of fluids or use of fluids not approved for use in commercial heating and cooling systems can damage coils and system components. For selection and application of heat transfer fluids, always follow the manufacturers' recommendations including treatment, mixing and filling. Warranty will be void if coil damage results from misapplication or improper treatment of the heat transfer fluid.

Some systems may use CPVC piping. Do not use propylene glycol with CPVC.

## BEFORE START-UP

Remove tie-down bolts, straps and blocks on fan and compressor vibration isolators, tilt equipped heat pipes and enthalpy/desiccant wheels if supplied.

## START-UP CHECK LIST

 	<b>Warning:</b> This unit is connected to high voltages. Electrical shock or death could occur if instructions are not followed. This equipment contains moving parts that can start unexpectedly. Injury or death could occur if instructions are not followed. All work should be performed by a qualified technician. Always disconnect and lock out power before servicing. DO NOT bypass any interlock or safety switches under any circumstances.
--	---

The start-up and operation must be in accordance with safe practices. Start-up must be performed by qualified personnel. Complete attached start-up record.

1. Set all associated electrical switches, controls, thermostats and main disconnect switch to "OFF" position.
2. Close all manual valves and field piping valves.
3. Before startup, review the Unit Function (mounted on the control panel door) and all control manuals supplied with this equipment. On units with heating sections, please follow the start-up procedure in the heating manuals. (Pack, DJ, DG, RT, HE, LM-K etc.)
4. Confirm all shipping materials has been removed. On units with semi-hermetic compressors, remove four spring isolator spacers and back off the top nut so that there is 1/32" (0.8mm) to 1/16" (1.6mm) space between the nut and neoprene spacer.
5. Check all bearings, drive and fan set screws for tightness. See TABLE I
6. Check drive alignment and belt tension. Refer to Maintenance, page 22.
7. Ensure that refrigerant lines and control capillary lines do not rub against cabinet or other lines.
8. Inspect all electrical wiring, both field and factory installed, for loose connections. Ensure fire alarm contact is installed, or jumpered if not required.
9. Turn disconnect switch ON (control switch is still off) and check the supply voltage. Voltage must be within 10% of rating plate. If not, contact the installing electrical contractor and have the voltage condition corrected before continuing start-up.
10. Crankcase heaters must be energized for at least twenty-four hours prior to starting the compressors. Check to see if heaters are working.
11. Attach service gauges. Some units are equipped with optional service valves at various locations. Ensure all service valves and post valves are back seated (fully open).
12. Rotation check.

Check rotation of all 3 phase motors. Motors were checked for correct rotation at the factory, if rotation is incorrect, turn off disconnect switch and reverse any two power leads leaving the disconnect. Re-check rotation.

**Caution:**

**Screw and Scroll compressors MUST be checked for proper rotation at startup. Permanent damage can occur if rotation is not correct.**

Scroll compressors running backwards will typically have low head pressure, high suction pressure and are usually noisy. Screw compressors MUST be checked with a phase meter before starting. If rotation is incorrect, instantaneous permanent damage can occur.

Reciprocating and Turbocor centrifugal compressors do not require rotational checks.

13. At all times of the year units equipped with water cooled condensers are shipped with a glycol solution in the condenser to prevent freeze damage during shipping. Depending on the application, the condensers may have to be flushed prior to use. Dispose of the glycol as required by local authorities having jurisdiction. Turn on the water supply and fill the condenser. Check for water leaks.
14. Turn on the service switch. Set controls to call for cooling. The supply fan will start as described in the unit function. The compressors should now be ready to start. Condenser fans will start as required when compressors are operating. If the compressor is equipped with an oil level sight glass, check the oil level.
15. Check the amperage draw of each motor and compressor. Refer to unit or motor rating plate for full load amps. At the unit, check and record the voltage while it is running. For 3 phase power the phase to phase voltage imbalance should be less than 2%. A 2% voltage imbalance can cause up to a 10% current imbalance that will overheat motor windings.

To calculate voltage imbalance (NEMA method) refer to the following example:

Phase to phase voltage readings:	235V 236V 230V
The average Voltage between legs is	233.7V (235+236+230)/3
Highest voltage deviation from average is:	233.7V – 230V = 3.7V
Voltage imbalance percentage = Highest deviation	divided by average X 100

$3.7 / 233.7 \times 100 = 1.6\%$  This imbalance is less than 2% and therefore is OK

**If voltage imbalance is greater than two percent (2%), turn off main disconnect and contact the installing electrical contractor to have the voltage condition corrected.**

16. Confirm field wiring voltage drop is less than 10% when equipment is operating.
17. For the unit to operate properly a system air balance must be performed to ensure correct air flow. Failure to do so can damage the equipment and/or building and can be a cause of poor indoor air quality.
18. Damper sections:
  - a) Flat mixing dampers:
 

Both the fresh air and return air dampers are fully open when the dampers are at a 45° angle when fully stroked. This provides optimum mixing of the air streams for this damper arrangement.

## b) Angle mixing damper:

Angle mixing section dampers open to an angle of 90° when fully stroked. This provides optimum mixing of the air streams for this damper arrangement.

19. Some units are equipped with an adjustable coil air bypass. This must be field adjusted during the system air balance to ensure proper air flow across the coil. Adjust the bypass to achieve coil pressure drop as stated on the submittal and/or the unit function sheet.
20. Allow system to operate until stable running conditions have been established.
21. Check and record amperage draw of each motor and compressor. Refer to unit label for running full load amps of motors and compressors.
22. Measure and record the suction and discharge pressures. On compressors equipped with an oil pump, measure and record net oil pressure. (net oil pressure is oil pressure minus suction pressure.).

Check and record the oil level on compressors that are equipped with oil level sight glasses.

## 23. Check system charge:

When thermostatic expansion valves (TX valves) are provided, the charge can be checked with the liquid line sight glass. Under normal operating conditions the sight glass is clear of bubbles. Refer to Charging Instructions.

NOTE: It is possible for conditions other than low refrigerant charge to cause the sight glass to bubble. Bubbling may occur when condenser fans cycles on, superheat setting is too low or filter-drier is plugged etc.

The TX valve superheat was checked and adjusted at the factory to maintain a superheat of 18°F (10°C) plus or minus 3°F (2°C) measured on the suction line 10 inches (250mm) from the compressor. This setting rarely requires readjustment. Should adjustment be necessary, refer to the TX valve manufacturers recommendations.

24. Condenser fan blades: Fan blades must be correctly positioned within the orifice for proper air flow.

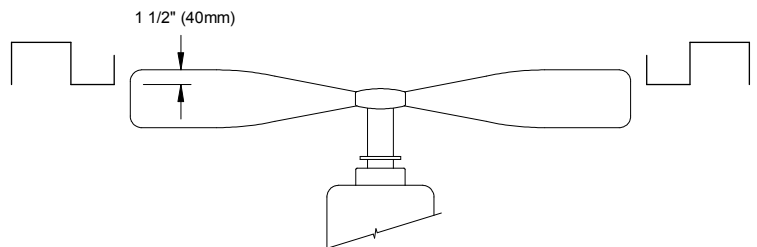

25. **Set all controls to the settings indicated on the wiring diagram.**
26. Re-install all access panels.
27. Remove any packing material or debris and dispose appropriately.

## OPERATION

**Warning:** This unit is connected to high voltages. Electrical shock or death could occur if instructions are not followed. This equipment contains moving parts that can start unexpectedly. Injury or death could occur if instructions are not followed. All work should be performed by a qualified technician. Always disconnect and lock out power before servicing. **DO NOT** bypass any interlock or safety switches under any circumstances.



**Warning:** Proper commissioning and start-up of the air handling system is the responsibility of the installing contractor. It is recommended that an air balance be completed by a certified air balancing contractor to insure the air volume being delivered matches the unit rating plate. Failure to perform a proper air balance can cause injury or death, damage to the equipment, property damage, system operational problems, or be a cause of poor air quality. Moisture carry over can result from improper air flow.



This unit may incorporate one or more functions and a variety of controls and options to suit individual requirements. A description of the unit functions and options is shown on the Electrical Data Sheet and unit wiring diagram. Carefully check your wiring diagram to verify that all remote controls are properly located and correctly field wired.

Some equipment may contain programmable unitary controllers or programmable logic controllers (PLC). Additional information can be obtained from the specific programmable control manufacturer. Often this information is available from the control manufacturer's website.

## REFRIGERATION CONTROLS

Refer to the wiring diagram and unit function for specific information. Standard pressure control settings are found in Table One, and the following notes. Application specific control settings are noted on the wiring diagram and in the unit function.

1. Hermetic Compressors:
  - a) Low Pressure Controls:

All compressors have an auto-reset low pressure control with contacts that open at low pressure and close when the pressure increases. See unit function for application specific pressure control settings or table two for typical pressure control settings.
  - b) High pressure controls:
    - i) Hermetic compressors, 6 tons and smaller.

High pressure controls are optional. These compressors are equipped with an internal pressure relief valve. On a high pressure condition, the internal pressure relief valve opens and relieves high pressure to the low side of the system. The internal valve will stay open until the pressures equalize.  
Note: No refrigerant is vented to atmosphere.
    - ii) Compressors larger than 6 tons.

High pressure controls are standard. The manual-reset contacts open when the system discharge pressure exceeds set point. The compressor is locked out until the control is manually reset. See *TABLE ONE* for standard pressure control settings.



- c) Overheat and Overload Protection:  
Hermetic compressors are typically supplied with either a winding thermostat or current sensing overload device. These are capable of sensing motor overheating caused by a shortage of gas, refrigerant system restrictions, single phasing or locked rotor conditions.  
Note: Winding thermostats can stay open for up to twenty four hours under some conditions.
2. Semi-Hermetic Compressor:
  - a) High and Low Pressure Control:  
The manual-reset high pressure control contacts open when the discharge pressure exceeds setpoint de-energizing the control circuit. The low pressure control is auto reset. See unit function for application specific pressure control settings or Table One **Error! Reference source not found.** for typical pressure control settings.
  - b) Overheat and Overload Protection:  
Semi-hermetic compressors are equipped with solid state motor protection with three motor winding temperature sensors. These Compressor Protection Modules (CPM) typically have a two minute anti-short cycle timer, for addition compressor protection.
  - c) Oil Pressure Safety Control:  
Semi-hermetic compressors are lubricated by a positive displacement oil pump. The compressor is protected against a loss of lubrication by the manual reset oil pressure safety control. This control senses the differential pressure between the oil pump discharge and the crankcase. A two minute delay serves to avoid shut down during short fluctuations in oil pressure.
3. Low Ambient Compressor Lock-Out:  
These controls will prevent the cooling system from starting when the ambient temperature is too cold and are provided as standard. The low ambient control may be part of the system controller or a separate device.
4. Head Pressure Control:  
Head pressure controls are designed to maintain an adequate operating head pressure, to allow the TX valve and other components to work correctly. Low head pressures can cause flashing in the sight glass, TX valve underfeeding and low system capacity.

Engineered Air systems are custom built and may employ any of several different methods of controlling head pressure.

- a) Above 50°F (10°C) ambient (Standard):  
Condenser Fan Cycling (CFC) head pressure controls will cycle fans to maintain proper head pressure on cooler days. See TABLE ONE for standard pressure control settings.
- b) Above 20°F (-7°C) ambient (Optional):  
Engineered Air Flash Intercooler is used with nested CFC controls to allow a floating head pressure. The intercooler eliminates flash gas at the TX valve. Refer to unit function for operating data on these systems.
- c) Above 0°F (-18°C) ambient (Optional):  
Variable speed condenser fan motors or inlet dampers on condenser fans will vary air flow to control head pressure. Refer to unit function for a description of operation.
- d) Above -40°F (-40°C) ambient (Optional):  
Condenser flooding head pressure controls are used to control the effective surface area of the

condensers during low ambient operation. These systems DO NOT USE pressure actuated fan cycling controls. Condenser fans are either constant run or cycled by ambient temperature. Refer to the valve manufacturers' literature for information regarding operation of these valves. Refer to unit function for a description of system operation.

5. Pumpdown System (Optional):

Depending on options, the cooling system may include a liquid line solenoid for refrigerant control and management, the control circuit may be wired for:

- a) solenoid drop, or
- b) single pumpdown, or
- c) recycling pumpdown, depending on the specific application.

6. Hot Gas Bypass (Optional):

Hot gas bypass is provided on systems to prevent frost formation on the evaporator coil during low load conditions.

The hot gas valve will start to open at a pressure that corresponds to approximately 34°F (1°C) coil temperature. All compressors equipped with unloading should be fully unloaded before hot gas starts to open.

7. Cylinder Unloading (Optional)

This is a form of capacity control on some compressors that reduces the pumping capacity of the compressor during low load conditions. Unloading may be activated by the control system or by a pressure actuated Cylinder Unloading Control (CUC).

NOTE: Semi-hermetic compressors with unloading require special heads and gaskets on the unloading cylinders.

8. Water Cooled Systems (Optional)

If the system is equipped with a water cooled condenser, set the water flow valve to maintain a saturated discharge temperature of approximately 105°F to 115°F (40°C to 46°C). This applies both to cooling tower systems and city water systems.

Typical water valve pressure setting:

R-22	= 230 psig (1580 kPa)	R-134a	= 150 psig (1040 kPa)
R-407C	= 270 psig (1870 kPa)	R-410A	= 370 psig (2550 kPa)

**Caution:**



When recovering refrigerant from a system equipped with a water cooled condenser, the water valve must be manually opened so water flows continuously through the condenser while the refrigerant is being recovered. Failure to do so can cause the condenser to freeze, which will permanently damage the condenser.

## REFRIGERANT HANDLING

Recovery, reuse, recycling, reclamation, and safe disposal of refrigerant is the only acceptable practice today. Venting of refrigerant into the atmosphere during installation or servicing is unacceptable. To avoid damage, use an accepted refrigerant recovery system whenever removing refrigerant. When working with refrigerants you must comply with all local government safety and environmental laws.

**Caution:**

Environmental laws govern the safe handling of refrigerants. Only personnel qualified to safely handle refrigerant may service this equipment. All refrigerant must be handled safely and responsibly. Records must be kept as required by the authorities having jurisdiction.

When servicing the refrigeration system, the refrigerant must be properly recovered to prevent release to atmosphere. Always use the same refrigerant as indicated on the unit rating plate.

**Do not change the type of refrigerant in the system. Warranty is void if refrigerant type is changed.**

Zeotropic refrigerants (e.g. R410A, R407C, R404A), must be charged into the system as a liquid. Care must be taken to introduce the refrigerant safely.

## COMPRESSOR OIL

Several types of oil are used by compressor manufacturers. The different types of oil cannot be mixed or interchanged. Consult the compressor manufacturer for the correct type, viscosity and quantity of oil used in the compressor.



On larger compressors, it is a good practice to do an acid test yearly. If the oil is acidic, discolored or has a bad smell, change the oil and take corrective action to stop acid formation.

### Oil Level

Small Hermetic compressors have no visual means of determining oil level. In the case of a leak, if the amount of oil lost is small and can be reasonably calculated, this amount should be added to the compressor. If there is a major loss of oil, the service personnel must remove the compressor, drain the oil completely and add the compressor manufacturers measured oil charge for replacement compressors before placing the compressor into operation. Contact the compressor manufacturer for the type and quantity of oil required.

Larger hermetic, semi-hermetic and screw compressors are equipped with an oil level sight glass. Consult compressor manufacturer for correct oil level. The oil level sight glass is typically between 1/4 and 3/4 full. Excessive oil in the system can damage the compressor.

## SHUTDOWN PROCEDURE

<b>Warning:</b>  	Electrical shock or death can occur if instructions are not followed. This equipment contains moving parts that can start unexpectedly. Injury or death could occur if instructions are not followed. All work should be performed by a qualified technician. Always disconnect power before servicing. <b>DO NOT</b> bypass any interlock or safety switches under any circumstances.
---	--

1. Temporary Shutdown  
To shut the unit down for a short time (such as for inspection or service). Shut of the service switch in the main control panel then turn off the main disconnect.
2. Re-Startup after Temporary Shutdown
  - a) Turn on main disconnect for the unit.
  - b) After the crankcase oil is warm again, turn on service switch.
3. Extended Shutdown  
Note: Leaving the main power on will keep the crankcase heaters energized and will not harm the system.
4. Re-Start After Extended Shutdown
  - a) If the main power was off, re-connect main power and allow 24 hours for crankcase heaters to work prior to start-up of compressors.
  - b) If main power was left on, check to ensure the crankcase heaters are still operating. If not, replace them and allow at least 24 hours before starting the compressor.
  - c) Follow the steps in the initial start-up procedure.

## CHARGING INSTRUCTIONS

Charging a system should be done at design head pressure (typically at 130°F (55°C) saturated discharge temperature). Condenser air flow can be temporarily restricted to simulate this condition.

1. Standard systems down to 50°F (10°C) ambient temperature:  
Raise the head pressure to a saturated discharge pressure that corresponds to 130°F (54°C). Charge refrigerant into the system slowly until the system sight glass is clear. The system must be at design air flow and load.
2. 20 to 50°F (-7 to 10°C). Systems with Engineered Air Flash Intercooler:  
If system is equipped with liquid line sight glass, Charge system until the liquid line sight glass is clear. When the head pressure is lower than this, this sight glass may bubble without affecting system capacity.

3. If the system is equipped with an Engineered Air Flash Intercooler sight glass only, raise the head pressure to a value corresponding to 130°F (54°C). Charge system until the flash intercooler sight glass is clear. Add additional refrigerant until the liquid line entering the intercooler is subcooled 5°F (2.7°C).
4. Charging instruction for a capillary tube system:  
Install temperature probes on the suction line (six to eighteen inches from the compressor), and the liquid line just before the cap tube. With a full load condition, charge the system until the suction line superheat is between 12 and 18°F (6.6 and 9.9°C) superheat and the liquid line subcooling is approximately 5°F (2.7°C).

## ENGA INTERCOOLER

The Engineered Air Intercooler is a heat exchanger installed between the TX valve and the distributor to reduce flash gas at the TX valve under adverse operating conditions.

## CONTROL SETTINGS

The following settings of the adjustable controls are acceptable for most applications. Refer to unit function and wiring diagram for settings specific to your unit.

Single and two stage ductstat: 55 – 70°F (13 – 21°C).

Single, two stage and modulating space thermostat: 68 – 74°F (20 – 23°C).

Remote temperature selector: 60 – 70°F (16 – 21°C).

Mixed air temperature controller: 55°F (13°C).

Low discharge air limit: 40°F (5°C).

Ambient control: 50 – 70°F (10 – 21°C).

Economizer ambient changeover control: 70 – 75°F (21 – 24°C).

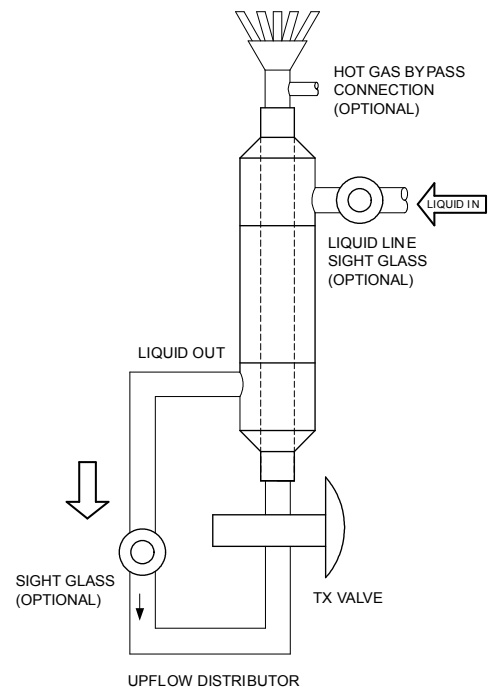

## MAINTENANCE

**Warning:**

This unit is connected to high voltages. Electrical shock or death could occur if instructions are not followed. This equipment contains moving parts that can start unexpectedly. Injury or death could occur if instructions are not followed. All work should be performed by a qualified technician. Always disconnect and lock out power before servicing. **DO NOT** bypass any interlock or safety switches under any circumstances.

**Warning:**

Follow the cleaning instructions and recommended inspection schedule to reduce the risk of mold or other bacterial growth. Property damage or personal injury claims may result from mold or biological growth arising from improper installation, inadequate maintenance, or failure to inspect. Engineered Air has no responsibility for and makes no express or implied warranties regarding mold or bacterial growth or any other indoor air quality issues. If mold or biological growth is present, determine and fix the cause. Properly remove and dispose of the contamination. Properly clean and sanitize the affected area using only approved sanitizers suitable for HVAC equipment.

To provide a maintenance history, It is recommended that the owner have a maintenance file for each unit. **The following maintenance instructions are to be carried out each spring and fall or as otherwise indicated by qualified service personnel.**

**Caution:**

**Label all wires prior to removal when servicing controls or critical components. Wiring errors can cause improper and dangerous operation.**



**Verify proper operation after servicing.**

## ELECTRICAL

1. Check all wiring for loose connections.
2. Check voltage at unit (while in operation).
3. Check amperage draw against unit rating plate.
4. Where possible, all contactors should be inspected to ensure that contacts are clean and are making good contact. If contacts are abnormally pitted or burned badly, replace contactor. Single phasing and motor burnouts can result from bad contacts.

## BELT ADJUSTMENT

For maximum belt and bearing life, pulley alignment and belt tension must be properly maintained. Only replace with belts of the proper type and size.

NOTE: If belts are too tight or improperly aligned, the life expectancy of the motor(s), fan bearings and belt(s) are reduced.

Alignment: Pulleys must be aligned to within 1/16" per foot (1mm per 760mm) of span.

**FOR FANS EQUIPPED WITH SPIDER BRACKETS:**

A properly adjusted V-belt rides the inside of the pulley faces. Because the sides of the belt wedge in the pulleys, the V-belt does not have to be extremely tight. It should be as loose as possible without slipping in the pulley grooves.

Belt deflection: 3/4 " (19mm) for each foot (300mm) of span between the pulleys.

**FOR FANS EQUIPPED WITH PILLOW BLOCK BEARINGS:**

Belt Deflection: Allow 1/64" (0.4mm) of deflection for each 1" (25.4 mm) of span length.

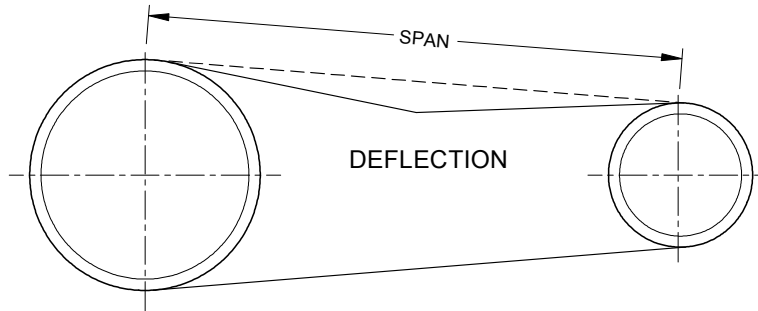

**⚠ CAUTION:** Excessive belt tension is the most frequent cause of belt wear, bearing wear and noise.

SET SCREWS

Check set screws on fan wheel, fan bearings, fan and motor pulleys for looseness on the shaft. Tighten where required. IT IS IMPORTANT TO PERFORM THIS CHECK BEFORE INITIAL START-UP, AFTER A RUN-IN PERIOD OF 2 WEEKS AND THEN ON 4 MONTH INTERVALS.

**⚠ CAUTION:** OVERTIGHTENING SET SCREWS CAN DAMAGE BEARINGS.

BEARING SETSCREW TORQUES

Shaft diameter	NTN	KOYO	NTN	KOYO	DODGE
Type	UC SERIES (set screw)		UK SERIES (adapter sleeve locknut)		SC 203-215 SERIES
3/4" (19mm)	35 in-lb (3.9 Nm)	35 in-lb (4.0 Nm)	Install the washer and lock nut; tighten the nut fully by hand.  Apply a punch or screw driver into the notch of the nut and tap it with a hammer. Stop tapping after the nut has turned 60° to 90°. Do not strike the seal.  Bend the tab on the rim of the washer, which is in line with the notch of the nut.  If a tab does not line up with a notch, tighten the nut further. DO NOT BACK THE NUT OFF.	66 - 80 in-lb (7.5 - 9 Nm)	
1" (25mm)	35 in-lb (3.9 Nm)	35 in-lb (4.0 Nm)		126 - 156 in-lb (14 -18 Nm)	
1 3/16" (30mm)	43 in-lb (4.9 Nm)	35 in-lb (4.0 Nm)		126 - 156 in-lb (14 -18 Nm)	
1 7/16" (37mm)	51 in-lb (5.8 Nm)	75 in-lb (8.5 Nm)		126 - 156 in-lb (14 -18 Nm)	
1 11/16"(43mm)	69 in-lb (7.8 Nm)	75 in-lb (8.5 Nm)		228 -272 in-lb (26 -31 Nm)	
1 15/16"(49mm)	69 in-lb (7.8 Nm)	155 in-lb (17.5 Nm)		228 -272 in-lb (26 -31 Nm)	
2 3/16"(56mm)	87 in-lb (9.8 Nm)	155 in-lb (17.5 Nm)		228 -272 in-lb (26 -31 Nm)	
2 7/16"(62mm)	147 in-lb (16.6 Nm)	155 in-lb (17.5 Nm)		228 -272 in-lb (26 -31 Nm)	
2 11/16"(68mm)	173 in-lb (19.6 Nm)	248 in-lb (28.0 Nm)		228 -272 in-lb (26 -31 Nm)	
2 15/16"(75mm)	173 in-lb (19.6 Nm)	248 in-lb (28.0 Nm)		228 -272 in-lb (26 -31 Nm)	

Refer to bearing manufacturers' literature for all other types of bearings.

### LUBRICATION OF FAN BEARINGS

Some fans have permanently lubricated sealed ball bearings which should not require lubrication. These bearings are factory packed 30 to 50% full. **Bearings that require lubrication should be greased while the bearing is rotating slowly, with the following quantities of a lithium base lubricant. DO NOT OVERGREASE. DO NOT USE NON-LITHIUM BASED GREASE.**

Extended lubrication lines may be provided. Tubing is not factory filled.

### RECOMMENDATIONS FOR BALL BEARINGS

Bearing Temperature ° F (°C)	Re-Greasing Interval		
	Clean	Dusty	Dusty & Wet
Under 120 (50)	2 ½ Years	Yearly	4 Months
Under 158 (70)	Yearly	4 Months	1 Month

Shaft Dia.	3/4" (19mm)	1" (25mm)	1 3/16" (30mm)	1 7/16" (37mm)	1 11/16" (43mm)	1 15/16" (49mm)	2 7/16" (62mm)	2 15/16" (75mm)
Grease	0.06 oz. (1.8g)	0.12 oz. (3.3g)	0.20 oz. (5.6g)	0.23 oz. (6.5g)	0.27 oz. (7.7g)	0.36 oz. (10.3g)	0.53 oz. (14.9g)	1.00 oz. (31.0g)

For additional information refer to the fan and/or bearing manufacturers' literature.

### LUBRICATION OF DODGE FAN BEARINGS

#### **Suggested Re-lubrication Schedule (Months)\* for Dodge Ball Bearing Pillow Block**

Speed (RPM)	500	1000	1500	2000	2500	3000	3500	4000	4500
Shaft DIA.									
1/2" - 1 1/16"	6	6	5	3	3	2	2	2	1
1 15/16" - 2 7/16"	6	5	4	2	2	1	1	1	1
2 11/16" - 2 5/16"	5	4	3	2	1	1	1		
3 7/16" - 3 15/16"	4	3	2	1	1				

\* Suggested initial greasing interval. . If safety permits, re-lubricate while running until some purging occurs at seals. Adjust lubrication frequency depending on condition of purged grease. Hours of operation, temperature and surrounding conditions will affect the re-lubrication frequency required. For 24 hour operation double the lubrication frequency.

Lubricate with a multipurpose NLGI No. 2 or No. 3 ball bearing grease having rust inhibitors, antioxidant additives and a minimum viscosity of 500 SSU at 100°F (38°C). Some examples of grease having these properties are:

Shell	Alvania RL 2
Mobil	Mobilith SHC220
Exxon	Ronex MP

Lubricate bearings prior to extended shutdown or storage and rotate shaft monthly to aid corrosion protection.



**Suggested Re-lubrication Schedule (Months)\* for Dodge Spherical Roller Bearing  
- Solid Pillow Block**

Speed (RPM)	500	1000	1500	2000	2500	3000	3500	4000	4500
Shaft DIA.									
1 <sup>3</sup> / <sub>16</sub> " – 1 <sup>7</sup> / <sub>16</sub> "	6	4	4	2	1	1	1	1	<sup>1</sup> / <sub>2</sub>
1 <sup>11</sup> / <sub>16</sub> " – 2 <sup>3</sup> / <sub>16</sub> "	4	2	1 <sup>1</sup> / <sub>2</sub>	1	<sup>1</sup> / <sub>2</sub>	<sup>1</sup> / <sub>2</sub>	<sup>1</sup> / <sub>2</sub>	<sup>1</sup> / <sub>2</sub>	<sup>1</sup> / <sub>2</sub>
2 <sup>7</sup> / <sub>16</sub> " – 3 <sup>7</sup> / <sub>16</sub> "	3	1 <sup>1</sup> / <sub>2</sub>	1	<sup>1</sup> / <sub>2</sub>	<sup>1</sup> / <sub>2</sub>	<sup>1</sup> / <sub>4</sub>	<sup>1</sup> / <sub>4</sub>		
3 <sup>15</sup> / <sub>16</sub> " – 4 <sup>15</sup> / <sub>16</sub> "	2 <sup>1</sup> / <sub>2</sub>	1	<sup>1</sup> / <sub>2</sub>	<sup>1</sup> / <sub>4</sub>					

\* Suggested initial greasing interval. If safety permits, re-lubricate while running until some purging occurs at seals. Adjust lubrication frequency depending on condition of purged grease. Hours of operation, temperature and surrounding conditions will affect the re-lubrication frequency required. For 24 hour operation double the lubrication frequency.

Lubricate with a multipurpose roller bearing NLGI No. 2 having rust inhibitors and antioxidant additives, and a minimum oil viscosity of 500 SSU at 100°F. Some examples of grease having these properties are:

- Shell           Alvania No. 2
- Mobil          Mobilith AW2
- Mobilith SHC100
- Texaco         Premium RB2
- American      Rykon Premium 2

Lubricate bearings prior to extended shutdown or storage and rotate shaft monthly to aid corrosion protection.

**Suggested Re-lubrication Schedule (Months)\* for Dodge Spherical Roller Bearing  
- Split Pillow Blocks**

Speed (RPM)	500	750	1000	1500	2000	2500	3000	3500	4000	** oz.
Shaft DIA.										
1 <sup>7</sup> / <sub>16</sub> " – 1 <sup>15</sup> / <sub>16</sub> "	6	4 <sup>1</sup> / <sub>2</sub>	4	4	3 <sup>1</sup> / <sub>2</sub>	2 <sup>1</sup> / <sub>2</sub>	2 <sup>1</sup> / <sub>2</sub>	1	1	0.05
2 <sup>3</sup> / <sub>16</sub> " – 2 <sup>11</sup> / <sub>16</sub> "	5	4 <sup>1</sup> / <sub>2</sub>	4	2 <sup>1</sup> / <sub>2</sub>	2 <sup>1</sup> / <sub>2</sub>	1 <sup>1</sup> / <sub>2</sub>	<sup>1</sup> / <sub>2</sub>	<sup>1</sup> / <sub>4</sub>	<sup>1</sup> / <sub>4</sub>	0.75
2 <sup>15</sup> / <sub>16</sub> " – 3 <sup>15</sup> / <sub>16</sub> "	4 <sup>1</sup> / <sub>2</sub>	4	3 <sup>1</sup> / <sub>2</sub>	2 <sup>1</sup> / <sub>2</sub>	1 <sup>1</sup> / <sub>2</sub>	1	<sup>1</sup> / <sub>2</sub>			2.00
4 <sup>7</sup> / <sub>16</sub> " – 4 <sup>15</sup> / <sub>16</sub> "	4	4	2 <sup>1</sup> / <sub>2</sub>	1	<sup>1</sup> / <sub>2</sub>					4.00
5 <sup>7</sup> / <sub>16</sub> " – 5 <sup>15</sup> / <sub>16</sub> "	4	2 <sup>1</sup> / <sub>2</sub>	1 <sup>1</sup> / <sub>2</sub>	1						7.00

\* Suggested initial greasing interval. Remove bearing cap and observe condition of used grease. Adjust lubrication frequency as needed. Hours of operation, temperature and surrounding conditions will affect the re-lubrication frequency required. Clean and repack bearing annually. Remove old grease, pack bearing full and fill housing reservoirs on both sides of bearing to bottom of shaft. For 24 hour operation double the lubrication frequency.

\*\* Grease to be added at each interval.

Lubricate with a multipurpose roller bearing NLGI No. 2 having rust inhibitors and antioxidant additives, and a minimum oil viscosity of 500 SSU at 100°F. Some examples of grease having these properties are:

- Shell           Alvania No. 2
- Mobil          Mobilith AW2
- Mobilith SHC100
- Texaco         Premium RB2
- American      Rykon Premium 2

Lubricate bearings prior to extended shutdown or storage and rotate shaft monthly to aid corrosion protection.

#### Static Oil Lubrication

Use only highest quality mineral oil with a minimum viscosity of 100 SSU at the oil's operating temperature. The oil's operating temperature is approximately 10°F greater than the bearing's housing. SAE values having this viscosity at the following operating temperature are:

150° - SAE 20      160° - SAE 30      180° - SAE 40

Static oil level should be at the center of the lower-most roller (do not overfill).

Complete lubrication change should be made annually.

### MOTOR LUBRICATION

Refer to motor manufacturer for lubrication recommendations.

On motors having grease drain plugs, remove the plugs and operate the motor for 15 minutes before replacing plugs. **DO NOT OVER GREASE.**

#### RECOMMENDED MOTOR LUBRICATION INTERVALS

Hours Service Per Day	Up to 7.5 HP Up to 5.6 kW	10 to 40 HP 7.5 to 29.8 kW	Over 40 HP Over 29.8 kW
Less than 12	5 Years	3 Years	1.5 Years
More than 12	2 Years	1 Year	9 Months

NOTE: Motors that run in severe conditions should be greased as specified by the motor manufacturer.

### FILTERS

Filter-changing intervals can be based on the pressure drop across the filter or by calendar scheduling or visual inspection. Scheduled intervals should be between one and six months, depending on the pollutant loading from indoor and outdoor air. More-frequent changes may be required during the economizer season.

**Units that operate with high levels of outside air should have filters removed (or moved to winter filter location if available) during the winter months in areas that have heavy frost or snow.**

Plugged or excessively dirty filters can cause damage to the equipment. See submittal record for filter quantities, sizes and types. Use same size and type for replacement.

- A. High Velocity Permanent:  
It is important that the filters be checked and cleaned regularly during the period immediately following installation, in order to determine the best service interval. To clean, rinse with water. Shake off excess water and re-install. These filters do not require an oil adhesive.
- B. Pleated Throwaway and/or Replaceable Media (Cartridge, Bag):  
Replacement filters can be obtained from any Engineered Air representative.

In some applications the used filters/media may contain chemical or biological hazards. All local, regional and national regulations for safety and disposal should always be followed.

## CONTROLS

Annually clean and recalibrate all controls, check for proper operation, and repair or replace any faulty controls. Check all damper hardware settings every three months. Replace blown fuses with equivalent size and type fuse. Failure to do so can result in damage to the unit.

## CONTROL ENCLOSURE VENTILATION

Control enclosures are often ventilated in summer to provide component cooling. A manually adjustable slide damper is provided for adjustment and seasonal shut off. The slide damper should be closed for winter operation and opened for summer operation.

## OUTDOOR AIR INTAKES, MIXING SECTIONS AND DAMPERS

Outdoor air intakes, screens, and adjacent areas shall be checked semi-annually for cleanliness, integrity and proper operation. Adjust dampers where required.

## COILS

Inspect coils and drain pans for cleanliness and biological growth once per year during the cooling season or more often as required.

**Warning:**

**Dirty coils can be a cause of poor air quality. Failure to maintain clean coils can cause injury or death, damage to the equipment, property damage or system operational problems. Moisture carry over can result from dirty coils.**

The external surface of finned coils can be cleaned using a low pressure water spray and a brush. Coil fins are easily damaged. Do not use high pressure steam or water to clean coils; it will permanently damage the coil. When using cleaning additives or solutions they must be compatible with the coil materials or coatings. Use a fin comb to straighten any damaged or bent fins.

### Coil Winterization:

Water coils that are not in use must be protected from freezing. Coils should be drained and blown out with compressed air and then filled and drained several times with appropriate strength pre-mixed inhibited HVAC glycol or other suitable fluid.

## HEATING

Follow maintenance procedures for applicable Pack, DJ(E), DG, RT, HE, LM-K electric heat section etc.

## REFRIGERATION

### Seasonal Maintenance

1. On semi-hermetic and screw compressors, check compressor oil level and add refrigerant oil if necessary.
2. Check operating temperature and pressures.
3. On units with sight glasses, check for leaks. There should be no foaming under steady state operation.
4. Condensing Section:

Water Cooled - With time, condensers can foul with mineral deposits from the water, resulting in a reduced heat transfer capacity and increased refrigerant head pressure. Should this condition occur, the condenser coil should be chemically cleaned or replaced.

Air Cooled – The external surface of finned coils can be cleaned using a low pressure water spray and a brush. Coil fins are easily damaged. Do not use high pressure steam or water to clean coils; it will permanently damage the coil. When using cleaning additives or solutions they must be compatible with the coil materials or coatings. Use a fin comb to straighten any damaged or bent fins.

5. Inspect refrigerant lines for evidence of oil leaks.
6. Check condenser fans and tighten set screws.

**NOTE:** Air flow is restricted by dirty coils, dirty filters, slipping fan belts etc. This will reduce cooling capacity and coil frosting can occur.

Table One		Refrigerant			
		R-22	R407C	R134a	R410A
Low pressure control	Cut In	60 psi (410 kPa)	60 psig (410 kPa)	30 psig (210 kPa)	105 psig (720 kPa)
	Cut Out	30 psig (210 kPa)	30 psig (210 kPa)	10 psig (70 kPa)	75 psig (520 kPa)
High pressure control NO RECEIVER	Cut Out	415 psig (2850 kPa) Manual reset	410 psig (2830 kPa) Manual reset	275 psig (1890 kPa) Manual reset	610 psig (4200 kPa) Manual reset
High pressure control UPW (Water cooled condenser – auto reset)	Cut In	175 psig (1210 kPa)	200 psig (1380 kPa)	150 psig (1030 kPa)	340 psig (2340 kPa)
	Cut Out	275 psig (1900 kPa)	325 psig (2240 kPa)	250 psig (1720 kPa)	460 psig (3170 kPa)
High pressure control /w Receiver	Cut Out	The lower of: that noted above or the maximum rated working pressure of the receiver or 90% of the receiver PRV.			
Hot gas bypass Start to open pressure.		60 psig (410 kPa)	52 psig (350 kPa)	30 psig (210 kPa)	105 psig (720 kPa)
CFC1	Cut In	240 psig (1650 kPa)	290 psig (1990 kPa)	155 psig (1060 kPa)	400 psig (2750 kPa)
	Cut Out	180 psig (1240 kPa)	220 psig (1510 kPa)	105 psig (720 kPa)	300 psig (2070 kPa)
CFC2	Cut In	260 psig (1790 kPa)	310 psig (2130 kPa)	170 psig (1170 kPa)	470 psig (3240 kPa)
	Cut Out	200 psig (1370 kPa)	240 psig (1650 kPa)	120 psig (820 kPa)	350 psig (2410 kPa)
Tandem compressor c/w compressor loading control (CLC)	Cut In	85 psig (585 kPa)	98 psig (675 kPa)	46 psig (315 kPa)	150 psig (1030 kPa)
	Cut Out	65 psig (450 kPa)	58 psig (400 kPa)	33 psig (230 kPa)	115 psig (790 kPa)

Cylinder Unloading Controls (CUC) should be set to be fully unloaded with a SST no less than 34°F (1°C) and with enough differential to prevent short cycling (no higher than 50-55°F (10-13°C) SST).











# START-UP RECORD

Unit Serial Number:

Date:

Model:						
All shipping material removed.						
All fan, bearing and pulley setscrews checked for tightness.						
Incoming power Voltage measurements:				Phase 1-2	V	
				Phase 2-3	V	
				Phase 3-1	V	
Rotation correct.						
Amperage measurements:		Phase 1	Phase 2	Phase 3		
Supply air blower					Compressor refrigerant pressure measurements	
Return air blower						
Burner motor					Suction	Discharge
Compressor 1					psig	psig
Compressor 2					psig	psig
Compressor 3					psig	psig
Compressor 4					psig	psig
Compressor 5					psig	psig
Compressor 6					psig	psig
Compressor 7					psig	psig
Compressor 8					psig	psig
Condenser fan 1					Ambient Temperature:	
Condenser fan 2						
Condenser fan 3						
Condenser fan 4						
Condenser fan 5						
Condenser fan 6						
Condenser fan 7						
Condenser fan 8						
Electric heat stage 1						
Electric heat stage 2						
Electric heat stage 3						
Electric heat stage 4						
Electric heat stage 5						
Electric heat stage 6						
Electric heat stage 7						
Electric heat stage 8						

**Note: Not all units have all of the components listed in the Start-Up Record.**

